

GYAN-VIGYAN SARITA: शिक्षा



A non-remunerative, non-commercial and non-political initiative to Democratize Education as a Personal Social Responsibility (PSR)

1st Supplement dt 1st Aug'17 to 4th Quarterly e-Bulletin

CONTENTS:

- [Editorial : राष्ट्रवाद और स्वतंत्रता](#)
- [Coordinators Views : A Systemic Tragedy - Education](#)
- [Online Mentoring : A Pictorial Perspective](#)
- [An Appeal – Gyan Vigyan Sarita](#)
- [Our Mentoring Philosophy](#)
- [Value of Patriotic Education](#)
- [Growing with Concepts:](#)
 - [Mathematics: Sets, Relations and Functions– Prof. SB Dhar](#)
 - [Physics: A.C. Circuits – S.K. Joshi](#)
 - [Chemistry : 2nd Law of Thermodynamics - Kumud Bala](#)
- Quizzes:
 - [Crossword Puzzle – Yoga - Prof. S.B. Dhar](#)
 - [Science Quiz – Kumud Bala](#)
- [Invitation For Contribution of Articles](#)

Editor-शिक्षा e-Bulletin : **Dr SB Dhar**

Coordinator-ज्ञान विज्ञान सरिता : **Dr Subhash Joshi**

Graphics Designer: **Devika Mathur**

Disclaimer : Views expressed in this bulletin are author's view and ज्ञान विज्ञान सरिता, Publishers of this bulletin, are not responsible for its correctness or validity

Rights of Publication

Core Committee of ज्ञान विज्ञान सरिता reserves right of moderation or publication of a contents of this e-Bulletin

Address: #2487, Betina, Mahagun Moderne, Sector-78, NOIDA, Uttar Pradesh, PIN: 201309,, (INDIA).

e-Bulletin – Eco-friendly: It is a considered decision to make this communiqué an e-Bulletin, and thus save paper. May please like to share it, but please do not print it, unless it is a must.

Our Website: <http://gyanvigyansarita.in/>;

E-mail: subhashjoshi2107@gmail.com



Wishing all a Happy Independence Day

Aim for the Best, but...

**Conceptual Representation
of
Online Mentoring
An Initiative To Bridge Gap between
Passionate Teachers
and
Desperate Students
A Selfless Endeavour
to
Democratize Education
with a sense of
Personal Social Responsibility (PSR)**



Online Mentoring From Texas



An Ideal Smart Training Hall

- Equipments at Mentoring Center**
- 1.Desk-/Lap-top
 2. WebCam
 3. Headset with Microphone
 4. Digital Pen
- AND**
Broadband-Internet
Connection: **Min. 20 Mbps**
and (1xN) GB monthly data
capacity; N= No of Hours
of Monthly sessions



Mentoring Centre



Cloud Internet



Screen-Sharing From Mentoring Centre To Learning Centre

Learning Centre

- Equipments at Learning Center**
- 1.Desk-/Lap-top
 2. WebCam
 3. Speakers
 4. USB Microphone
 5. Overhead Projector.
 6. UPS (For Continuous Power Supply to computer, internet modem and L&F)
- AND**
Broadband-Internet
Connection: **Min. 20 Mbps**
and (1xN) GB monthly data
capacity; N= No of Hours
of Monthly sessions



Mentoring-cum-Learning Centre (Demo)

- Important Links**
1. Good Internet Connectivity (Wired Broadband Connection)
 2. Subject-wise Coordinator for Each Session to Bridge Learning Gaps between Mentor & Students



Mentoring Centre

Learning Centre - 1

Learning Centre - 2

Learning Centre - 3

Learning Centre - n

Learning Centre - r

- Special Features**
1. Free and Open to all to adopt. Modify, change, correct
 2. Welcomes participation, promotion and facilitation on Zero-Fund-Zero-Asset (ZFZA) basis
 3. More details on Technological and Operational – please write on <http://www.gyanvigyanarita.in/contact/>



Set-up at Learning Centre



Learning Centre Directly on Desktop

Projector Connected to Computer



Learning Centre With Projector Display

... start, without loosing time, with whatever is available.



संपादकीय

राष्ट्रवाद और स्वतंत्रता

मनुष्य को प्राकृतिक अवस्था में तीन चीजों के अधिकार प्राप्त हैं : जीवन, स्वतंत्रता और संपत्ति। जब कभी इन अधिकारों पर अंकुश लगता है, तब मनुष्य सोचता है कि उसकी स्वतंत्रता प्रभावित हो रही है। मनुष्य की इच्छा रहती है कि उसके प्राकृतिक अधिकार हर हाल में सुरक्षित रहें।

कुछ विचारकों का मानना है कि हर प्रकार की भावना को व्यक्त करना चाहें वह देशहित में हो अथवा न हो, प्राकृतिक स्वतंत्रता है। उनके अनुसार ऐसी मानसिकता से देश की स्वतंत्रता प्रभावित नहीं होती है। पर यह अर्धसत्य है। पूर्ण सत्य यह है कि जब हम अपनी स्वतंत्रता का उपयोग क्षेत्र, समाज, भाषा, परिवेश और परिधान की विविधता से बाहर निकलकर सर्वकल्याण के लिये करते हैं, तब उससे समग्र देश का विकास होता है, विकासरूपी सूरज की किरणें सबतक पहुंचती हैं, विकासरूपी चांद की चांदनी सबके घरों में शीतलता बिखेरती है, और विकास की महकती हवा सबका मन मोहती है।

स्वतंत्रता का मतलब ही है, सबका विकास। स्वतंत्रता किताबी शब्द नहीं है। यह उनमें भी पाया जाता है जो कभी किताबों से वास्ता नहीं रखते। राष्ट्रवाद भी किताब से नहीं सीखा जाता है। स्वतंत्रता और राष्ट्रवाद, ये दोनों शब्द किसी विद्वान की दी गयी परिभाषा में भी नहीं समाते हैं। वास्तव में, हर व्यक्ति की अपने देश की भलाई के लिये सोचना, उसका अपनी सामर्थ्यभर देश के लिये कुछ करना और देश के प्रति आवश्यकता पड़ने पर अपना सर्वस्व समर्पण करने का भाव रखना ही राष्ट्रवाद है। स्वतंत्रता और राष्ट्रवाद एक दूसरे के पूरक हैं। एक की कमी, दूसरे को उच्छृंखल बना देती है, अव्यवस्थित कर देती है, पथभ्रष्ट कर देती है, अनुशासनहीन कर देती है, और अंत में सबका विकास रोक देती है।

विकास व्यवस्था से होता है। व्यवस्था अनुशासन से होती है। अनुशासन जिम्मेदारी से पैदा होती है। जिम्मेदारी राष्ट्र के प्रति समर्पण भरी सोच से उपजती है। यह समर्पण ही, स्वतंत्रता-

प्राप्ति और राष्ट्रवाद का मूल तत्व है। मूल यानि जड़ दीखती नहीं है पर जितनी गहराई तक जड़ें जाती हैं, उससे अधिक ऊंचाई तक वृक्ष ऊपर उठता है, स्वस्थ रहता है और मजबूत दीखता है।

अपने देश के प्रति समर्पण की पहचान करना बड़ा आसान होता है। एकांत में बैठो, अपने दिल की गहराई में झांको और स्वयं से पूछो कि क्या यह देश मेरा है, क्या यह धरती मेरी है, क्या यह हवा मेरी है, क्या इस हवा की महक मेरी है? फिर जो उत्तर मिले वही देशभक्ति है, वही राष्ट्रवाद है और उसी उत्तर का भाव स्वतंत्रता है।

देश की रक्षा 'हम' से नहीं 'मैं' से होती है। राष्ट्रवाद 'मेरा' से उपजता है न कि 'हमारा' से। 'हमारा' बहाना बना सकता है पर 'मेरा' कभी बहाना नहीं बनाता है क्योंकि 'मेरा' पर हर काम की जिम्मेदारी खुद की होती है और 'हमारा' भीड़ का अंग बन जाता है।

राष्ट्र की परख एक ऐसे जनसमूह से की जाती है जो एक भौगोलिक सीमा में, समान परंपराओं का पालन करते हुये, समान हितों की रक्षा करते हुये, समान भावनाओं से बंधा होता है, लेकिन भारत विविध भाषा-भाषी, और अनेक धर्मों के अनुनायियों वाला देश है। यह विभिन्न जातियों, और उपजातियों में विभक्त है। इसी कारण बहुत से विचारक भारत को राष्ट्र न मानकर एक भौगोलिक भाग मानते हैं। **सर जान शिले** कहते हैं, यह विचार कि भारत एक राष्ट्र है, राजनीतिशास्त्र इसे स्वीकार नहीं करता है। भारतवर्ष एक राजनीतिक नाम नहीं है, यह एक भौगोलिक भाग है, ठीक वैसे ही जैसे यूरोप, अफ्रीका आदि।

भारत हमेशा से ही राष्ट्रवाद व स्वतंत्रता का पोषक रहा है। परंतु पाश्चात्य जगत के राजनीतिक विशारदों की दृष्टि से वर्तमान राष्ट्रवाद 17वीं शताब्दी से अंकुरित होकर 1857 में पूर्ण हुआ। उन्नीसवीं शताब्दी का मध्यकाल राष्ट्रवाद का पोषक काल रहा।

अंग्रेजी शासन काल से अप्रसन्नता के कारण ब्रह्मसमाज के राजाराममोहनराय, आर्यसमाज के स्वामीदयानंद, रामकृष्णमिशन के स्वामीविवेकानंद, और थियोसाफिकलसोसायटी की श्रीमतीएनीबेसेंट आदि ने राष्ट्रवाद का संरक्षण स्वतंत्रता के लिये किया और विभिन्न क्षेत्रों में जन जागरण का कार्य अपने अपने तरीके से किया। राजाराममोहनराय को भारतीय राष्ट्रीयता का अग्रदूत माना जाता है। स्वामीदयानंद ने सत्यार्थप्रकाश में लिखा था कि विदेशी राज्य चाहें वह कितना ही अच्छा क्यों न हो, स्वदेशी राज्य की तुलना में कभी भी अच्छा नहीं हो सकता है।

अंग्रेजों ने भारत में अपनी शिक्षा प्रणाली लागू कर भले ही राज्य करने के लिये स्थानीय लोगों को तैयार किया पर सबसे अधिक इस शिक्षा प्रणाली का फायदा यह हुआ कि अंग्रेजी भाषा जानने के कारण यहां के लोगों को पश्चिमी देशों के साहित्य का अध्ययन करने का अवसर मिल गया। उन्होंने अंग्रेजी भाषा के ज्ञान होने पर पश्चिमी जगत के विद्वानों जान स्टुअर्ट मिल, हरबर्ट स्पेंसर, बर्क, मिल्टन, आदि की कृतियों को पढ़ा और उनकी स्वतंत्रता के प्रति विचारों से प्रेरित हुये।

राष्ट्रवाद वह भाव होता है जिसके तहत सैनिक देश की सीमाओं पर डटे रहते हैं। राष्ट्रवाद वह भाव होता है जिससे देश के नागरिक, देश के लिये बड़ी से बड़ी कुर्बानी दे देते हैं। राष्ट्रवाद वह उत्तेजना होती है जो हमें धर्म, भाषा, जाति से ऊपर उठकर देशहित में एक होने की शक्ति देती है। राष्ट्रवाद, संपूर्णता और सामूहिकता का उदाहरण होता है, और राष्ट्रवाद का अभाव वह कार्य होता है जब देश को एकता की जरूरत होती है तो कुछ लोग देश के हित का विरोध करने वालों के साथ खड़े दीखते हैं।

स्वतंत्रता आधुनिक काल का वह राजनैतिक दर्शन है जिसके बलबूते पर राष्ट्र अपनी इच्छानुसार कर्म करता है, और सबके जीवन को सबके सहयोग व संबंध के आधार पर, खुशहाल करने के बारे में सोचता है। संबंध अस्तित्व का आधार है। संबंध के बिना किसी का वजूद संभव नहीं होता है। संबंध का अर्थ है, सहयोग। संबंध निभाना, जिम्मेदार होना होता है। प्रकृति के साथ संबंध होने का तात्पर्य होता है उसके प्रति जिम्मेदार होना, उसकी रक्षा व संरक्षण के प्रति जिम्मेदार होना। ठीक यही बात, स्वतंत्रता के साथ भी है। यदि हम जिम्मेदार नहीं हैं तो हमारे लिये स्वतंत्रता का कोई महत्व नहीं है। जिम्मेदारी का आसान

भाषा में अर्थ है किसी की परवाह करना। जैसे, मां बच्चे की परवाह करती है, शिक्षक अपने शिष्य की परवाह करता है, और हम अपने पड़ोसी के बाहर जाने पर उसके घर की परवाह करते हैं। एक बात तय है कि स्वतंत्रता का अर्थ है, परिश्रम से देखभाल, न कि लापरवाही।

आजादी या स्वतंत्रता का महत्व समझने के लिये आवश्यक है कि हम पहले उस वातावरण में जीने की कल्पना करें, जहां आजादी न हो अर्थात् उस वातावरण को याद करें, जब हम गुलामी की सींकचों में बंधे थे, और अपने देश के बारे में सोचना देशद्रोह माना जाता था। कारण, आज की पीढ़ी अधिकांशतः उन लोगों की है जिन्होंने स्वतंत्रता की कीमत किताबों से जानी है, उन्होंने गुलामी का न तो वातावरण देखा है और न ही गुलामी के कारण होने वाले कष्टों को महसूस किया है।

स्वतंत्रता की मांग सभी करते हैं, परंतु इसे संभालने के लिये तैयार बहुत कम होते हैं। संभालने का मतलब होता है परिपक्व होना, और नकारात्मकता से दूर होना। स्वतंत्रता को संभालना तलवार की धार पर चलने जैसा होता है, जितना जोखिम भरा उतना ही जीवन से लबालब। स्वतंत्र होने का अर्थ यह नहीं है कि हमें युद्ध की परिस्थिति में किसी देश से हारने की भी स्वतंत्रता है, अपनी स्वतंत्रता बेंचने की भी स्वतंत्रता है, और दूसरों के दबाव में आकर अपने देश हित को नकारने की भी स्वतंत्रता है। यही सब न करना जिम्मेदार होना है।

भारतीय राजनीति में स्वतंत्रता प्राप्ति के 7 दशक बीत जाने के बाद भी ऐसे राजनेताओं अथवा राजनीतिक सूझबूझ रखने वालों की कमी है, जो केवल देशहित अथवा लोककल्याण के लिये नेता बनना स्वीकार किये हों। आजकल इस वर्ग में ऐसे लोगों का वर्चस्व बढ़ रहा है, जो केवल अपने लिये, अपने परिवार के लिये, और अपनी जाति अथवा धर्म के लिये सोचने लगे हैं। उनका कार्य सर्वजनहिताय कम और स्वहिताय ज्यादा हो रहा है। उनका कार्य, दूसरों की सेवा करना कम हो गया है, और अपने लिये धन अथवा पद कमाना ज्यादा हो गया है।

आज जब हमारा देश अपने बलबूते पर आगे बढ़ रहा है, समूचा विश्व हमारी बात सुनने को तैयार बैठा है, हमारी सुदृढ़ हो रही अर्थव्यवस्था की ओर सभी नजरें टिकाये हुये हैं, तब हमें भ्रष्ट आचरण वालों से सावधान रहना होगा। अगर हम ऐसा कर सके, तभी हमारी स्वतंत्रता सुदृढ़ होगी और चिरकालिक होगी। हमें

याद रखना होगा कि भ्रष्ट आचरण, धीरे धीरे गलत कामों का केंद्र बन जाता है और विदेशी ताकतें जो देश की स्वतंत्र व्यवस्था को अस्थिर करना चाहती हैं, उसी गलत कामों के केंद्र से अपना कार्य करने लगती हैं।

एक ऐसा वर्ग भी आजकल हमारे देश में पैदा हो रहा है जो सेना के जवानों को पत्थर मारने में बहादुरी समझता है, देशद्रोहियों के कार्यों की प्रशंसा करता है, पर देशहित के लिये कार्यों की समीक्षा के समय मूकदर्शक बन जाता है।

हमें हर समय अपनी स्वतंत्रता की रक्षा के लिये सजग रहना होगा। यह नहीं भूलना होगा कि सावधानी हटी, दुर्घटना घटी। हमें यह भी नहीं भूलना होगा कि हमारा महत्व मजबूत राष्ट्र से है, अगर राष्ट्र है तो हम हैं, हमारी व्यवस्था है, हमारी स्वतंत्रता है और हम स्वतंत्र हैं, अन्यथा हमारे लिये कुछ भी नहीं है। हमें अपने लिये, अपने समाज के लिये, अपने राष्ट्र के लिये जिम्मेदार होना होगा, पूर्ण समर्पण से, पूर्ण श्रद्धा से और स्थिर मन से। हमें राष्ट्र को देने के लिये आगे आना होगा न कि राष्ट्र से लेने की फिराक में रहना होगा।

बराक ओबामा के अनुसार, नामुमकिन मुसीबतों के वक्त जो लोग अपने वतन से प्यार करते हैं, वे उस समय को बदलने की भी ताकत रखते हैं। देशभक्ति तब जगती है जब हमारे अंदर यह भावना भर जाती है कि हम औरों से बेहरत हैं।

भारतीय संदर्भ में राष्ट्रवाद मानवतावाद से जुड़ा रहा है। यहां के संतों का मानना रहा है - संतों को सीकरी से क्या काम। कोउ नृप होय हमें का हानि, तात्पर्य हमें राज्य पर निर्भर नहीं रहना है, पर साथ ही साथ हमें अपने कर्तव्य से विमुख भी नहीं होना है।

शांति काल में स्वतंत्रता सुख का, आनंद का, वैभव का पोषण करती है और युद्ध काल में यह फकीरी का पोषण करती है। यही

फकीरी की सोच रखना राष्ट्रवादी होना है। एक समय हम राष्ट्र से कुछ ले रहे होते हैं, और ठीक दूसरे समय हम अपना सर्वस्व उसी राष्ट्र को दे रहे होते हैं। भामाशाह स्वतंत्रता के रक्षक भी हैं और स्वतंत्र भी हैं। राम हों, कृष्ण हों, शिव हों, महावीर हों, बुद्ध हों, सब राजपुत्र हैं, संप्रभु हैं, फिर भी राष्ट्रवाद की खोज में सत्ता को छोड़कर वनों में जाते रहे हैं, सत्य की खोज करते रहे हैं, ज्ञान की खोज करते रहे हैं, पर जन सामान्य से संवाद की सरिता बहाये रखे हैं।

सर्वपल्ली राधाकृष्णन कहते हैं कि हमें मानवता को उन नैतिक जड़ों तक वापिस ले जाना चाहिये जहां से अनुशासन और स्वतंत्रता दोनों का जन्म होता है।

नेल्सन मंडेला कहते हैं कि स्वतंत्र होना, अपनी जंजीर उतार देना मात्र नहीं है, बल्कि इस तरह जीवन जीना है कि औरों का सम्मान और स्वतंत्रता बढ़े।

अटलबिहारी बाजपेयी की कविता की पंक्तियां हमें सचेत करती हैं:

उस स्वर्ण दिवस के लिये आज से

कमर कसैं बलिदान करें

जो पाया उसमें खो न जायें

जो खोया उसका ध्यान करें

15 अगस्त, स्वतंत्रता दिवस पर, हमारी स्वतंत्रता के 70 वर्ष पूरे होने पर, सभी पाठकों को कोटि कोटि नमन और बधाई। हमारी स्वतंत्रता अक्षुण्य रहे, हम हमेशा अपने देश के प्रति निष्ठावान बने रहें, और साथ ही साथ **ज्ञानविज्ञानसरिता** के माध्यम से शिक्षा को सर्वजन तक निःस्वार्थभाव से पहुंचाते रहें, यही प्रार्थना ईश्वर से है। जयहिंद, जयभारत!

—00—

Ask not what your country can do for you -- ask what can you do for your country?

- John F. Kennedy.

An Appeal: Gyan Vigyan Sarita **A non-organizational initiative of a small set of Co-passionate Persons**

Philosophy: Personal Social Responsibility (PSR)

Objective: Groom competence to Compete among unprivileged children from 9th-12th in Maths and Physics, leading to IIT-JEE.

Financial Model: Zero-&Fund-Zero-Asset (ZFZA). It calls for promoters and facilitators to provide infrastructure for use to the extent they feel it is neither abused nor there is a breach of trust. And, reimbursement of operational expenses to the participators

Operation:

- a. **Mode:** Online since July'16, using Google Hangouts, a free we-conferencing S/w, with connectivity upto 15 nodes.
- b. **Participation:** Voluntary and Non-remunerative, Non-Commercial and Non-Political

Involvement:

- a. **As Promoter –**
 - i. Initiate a Learning Center,
 - ii. Sponsor a Mentor who is willing to join on certain terms,
 - iii. sponsor cost of operation and up-gradation of infrastructure to voluntary mentors,
 - iv. Sponsor Website.
- b. **As Facilitator –**
 - i. Provide space and infrastructure for **Online Mentoring Sessions (OMS)**, which is generally available, with a marginal add-on,
 - ii. Garner support of elite persons to act as coordinators at a Learning Centre.
- c. **As Participant –**
 - i. As a Mentor,
 - ii. As Coordinator,
 - iii. As Editor and or contributor of thought provoking articles for e-Bulletin, which are relevant to the initiative, and make it more purposeful and reachable to the target audience.
 - iv. As author of Chapters for Mentors' Manual, being uploaded as a Free Web Resource,

- v. Anything else that you feel can add value to the mission and make it more purposeful.
- vi. *Anything else that you consider to make this initiative to become more effective.*

Background: *The initiative had its offing in May'12, when its coordinator, a power engineer by profession, soon after submission of Ph.D. Thesis in April'12, at IIT Roorkee, at the age of 61 years, decided to mentor unprivileged students.*

SARTHAK PRAYASH, a Ghaziabad based NGO, warmly accepted the proposition and created a facility to mentor students from 8+ to prepare in mathematics and physics and prepare them for engineering entrance tests. They warmly reciprocated and created a class room.

*Experience in this selfless social work were used to navigate across without losing focus. He was associated with SUBODH FOUNDATION from Sept'15 to Sept'16 during which he published a monthly e-Bulletin **SUBODH-पत्रिका** to create visibility across persons who could make a difference.*

*In Sept'16, post transition, the mission has been continued as a non-organizational entity **Gyan Vigyan Sarita**, with a set of Four persons, including retired **Prof. SB Dhar**, Alumnus-IIT Kanpur, a middle aged **Shri Shailendra Parolkar**, Alumnus-IIT Kharagpur, settled at Texas, US and **Smt. Kumud Bala**, Retired Principal, Govt. School Haryana. Earlier, they were complementing the OMS. While, the initiative survived transition, a website: <http://gyanvigyansarita.in> has been launched. It contains under its **Menu: Publication>e-Bulletins**, and **>Mentors' Manual**. You may like to read them.*

Actions Requested: *May please like to ponder upon this initiative. **Queries**, if any, are heartily welcome. We would welcome your collective complementing in any of the areas listed at **Involvement**, above, to make the mission more purposeful and reachable to target children.*



A Systemic Tragedy - Education

Our country shall be celebrating completion of seven decades of Independence on 15th August, which in following years eventually will become a largest democracy in the world. Historically, education was a process of acquiring excellence in field of interest under a Guru, and there existed a strong bondage between गुरु-शिष्य. Lord T.B. Macaulay in 1835 created a major drift in educational policy which linked it to create earning opportunities, without which he branded education as useless. And then, jobs available to Indians were to faithfully serve British Empire in its growth and stability, without any dissidence. In this perspective and role on prevalent India emerging as most populated country with highest economic potential, educational requirement have changed a lot and needs introspection.

Barely a month ago, [why did PM](#), top person in government, administration and execution, and a person having grown from scratch, is required to remind pre-UPSC days to the IAS officers of batch 2015? At the inaugural session of Assistant Secretaries, he expressed dissatisfaction over relative progress of the country. He also emphasized upon need of boldness to dynamically transform the system to bring in positive change in system and lives of common man.

IAS is a most coveted career, by way of inspiration, selection, grooming and work culture. Now a day, many technocrats are there into the career. Moreover, irrespective of their academic discipline they develop a capability to grab basics of any new problem and take decisions. Despite, the author not being an IAS, having a long association with them during executive career, these views are unbiased and with all appreciation to the cadre. Nevertheless, there were discouraging experiences from some of the incumbents in this celebrity career. Is it not due to, the incumbents taking a path of least resistance, falling in line with the system aberrations, and using the logic of convenience? Is it not use of intrinsic capabilities to justify actions or inactions which were in contravention to the needs of dynamic change, instead of what is called upon them?

Readers are advised, not to be biased against IAS with these views, rather it needs to be introspected by **all scholars and professional in whatever role they are, either by choice or compulsion**. It is believed that this article would ignite introspection among elites, should they not lie in a blemished state of extorting society and nation with self-centric motives.

*Right from Confucius, Socrates to modern thinkers and philosophers, all have expressed their views on education; it is not mere collection of data or information, rather it has a projection in perpetuation of human civilization. **Education is about inculcating a thought process and an ability to analyze happening in its retrospective to explore the cause and invent remedies with better prospective consequence.** It is about growing and perpetuating for coexistence as an inseparable entity of society.*

*Quality of the thought process and ability to solve problems, intrinsic to education, is the only thing which discriminates biological equals. But, in reality elite families take pride in their descendants to carry their legacy, as perceived and imposed upon India by Macaulay. In order to accomplish this they go to any extent to plough their choicest resources. This has made educational environment extremely commercial and self-centric. As a result unprivileged children are, increasingly, getting distanced from able guidance, information and environment to become competitive. Moreover, with the growing communication and awareness, even under-privileged parents put in the best of their belongings with a hope that it might shape fortune of their child. A careful analysis would reveal that this anomaly continues to broaden and perpetuate with insignificant gains. **This scenario is leading to a serious capability crisis in a global arena where survival is of the fittest.***

Government policies and social welfare organizations claim numbers of equalizing unequals through various grants, reservations, scholarship etc. But, education is a transformation process and not a commodity which can be so easily equalized. In real sense, democratization of education demands opportunities to all, and equally accessible.

Gyan Vigyan Sarita (GVS) has been engaged in a mission to democratize education with a sense of Personal Social Responsibility (PSR) to groom competence to compete among unprivileged children. It is a non-organizational activity by a set of Four co-passionate persons who dedicate their time and efforts for the cause in non-remunerative, non-commercial and non-political manner. Efforts to mentor target children through Chalk-N-Talk, started five years ago, have culminated, a year ago, into Online Mentoring Sessions (OMS). This OMS is a non-proprietary and is a potential alternative to connect passionate and dedicated mentors, who are prepared to commit into it consistently, and the target students by motivating, mentoring and finger holding them to be enable them to compete. Since this model uses ICT, it is adaptable across geographical and demographic boundaries. Presently its limitation is medium of communication, which is Hindi and English language. Once mentors from other languages volunteer, it would diffuse regional and linguistic barriers too. Then, sky is the limit, subject to mentors choosing to volunteer, and their capacity to concurrently manage learning centers. Since, target students cannot garner requisite resources for OMS, learning centers are to be managed by promoters on Zero-Fund-&Zero-Assets (ZFZA) to GVS. These promoters can be social groups, schools, institutions, organizations, administration and/or government, having philanthropic and social welfare approach.

This initiative has been put across, through word of mouth, as much and as far as possible. With no regrets, it is placed on record that response to this selfless proposition, OMS, is extremely poor. Organizations and persons that were approached are broadly classified to explore generic reasons behind it, and are as under -

Group I: Institutions which have infrastructure, CSR potential and human resource. Apparently, they are too obsessed with their stature and unwilling to open across, despite being far away from the selfless proposition of OMS, with a sense of PSR, at the grass root level.

Group II: Government administrative systems equipped with resources and authority to bring in a change. But, they are too occupied in window dressing and firefighting with the issues of immediate concern.

Thus they are unable to either find time to address education at its basics.

Group III: Autonomous organizations, prima-facie, appreciate the merit of the proposition. But at the institutional level they fear of a backlash from the faculties, in place, who might not able to cope with inquisitiveness of students exposed to conceptually driven learning. These apprehensions, turning into reality, would jeopardize their commercial motives.

Group IV: Private School have acquired prime locations, but they are managed and administered by incompetent individuals who are busy in imparting education as a commodity and unprepared to accept any external intervention. At the same time their teachers and premises are occupied, in one way or the other, for commercial motives.

Group V: NGOs and Social Groups are seen to aim at raising funds with brilliant slogans, enjoying autonomy in their operation and spending. They are unprepared to interact with this mission, volunteering to complement their proclaimed mission selflessly and in a transparent manner. It raises a basic question that - **if their intentions are genuine and true to what they claim then why do they exercise non-transparency?** We request all to help us find an answer to this and pin-point fault if any in this mission. *Nevertheless, only Two of NGOs which deserve mention respectful mention to provide an access into their educational initiative are **Sunshine Society** and **Sarthak Prayash**. But, the number of target students that they are able to garner is insignificant to the efforts being put in by GVS.*

These experiences with organizations over a wide spectrum form an appropriate case to analyze **where are the aberrations? Is it into the system? Ideally systems must funnel synergy of its constituents to attain desired and expected results for achieving ecological, social and economic growth in a sustainable manner.** Systems, processes, especially in education are meant to transform society and prepare it for challenges ahead. **It is such a mammoth task that none can individually do it.** System need to be tuned to dynamics of change and provide a space for voluntary passion, dedication, commitment available from wherever, as long as it ensures sincerity, with continuity and consistency. **If it were there then why repetitive**

discouragement is meted to this initiative. Are systems really failing to be what it should?

Dr, Verghese Kurien, father of White Revolution in India, had said that *“while working, one must not hesitate to trespass boundaries of rules and regulations, with a clear vision to achieve the organizational objective selflessly”*. This is considered to be a **Mantra of Dynamic Change**. In an organization rules, regulations, systems and processes are laid down to define a roadmap for operation and performance. Check and balances, imbibed in them are based on experience of abuse of authority, in whatever way. No such man-made stipulation can be Zero-Defect, and they are the people who find ways and means to justify their actions and inactions. This is where the Mantra is an important tool for an honest performer. Problems do occur, and they scale up exponentially as one rises in position and responsibility. Having accepted that role, none should accept a red-carpet-walk, and be prepared to face them as an occupational hazard with clarity of vision and intentions. This is where **leadership** comes into picture.

Leader is one who creates work for self, and all in the system-matrix, to bring about a positive change wherever necessary, to ensure a sustainable growth, within and outside the system. If a leader works within framework of rules and regulations, without sensitivity and sensibility to the overall needs, is *he not fit to be an obedient subordinate?* If there are no problems then all managers, executives, administrators and leaders are a liability. Thus, they need to be thankful to the state of chaos which offers them an opportunity to prove their existence. Such a role requires taking a posture offensive to problems and not a defensive one, but, with a total judiciousness. Our former president **Late Dr. A.P.J. Abdul Kalam** had once said that *“a leader at work should always take blame of failures and pass on the credit of success to his teammates”*.

System and leadership are pyramidal and every pyramid has its sub-pyramid, supporting each other with a complex dependency. These systems descend

from government at national level to down below upto family, an elemental unit. Role of a head of system is no different than a leader. Modern management theories talk of participative management and it works in some way to resolve immediate and operational problems. But, onus of laying a roadmap into future lies with the leader only. As one ascends in system pyramid, it requires a different kind of growth, maturity and skill-set, over a wider horizon. It would be unfair to expect these traits in leaders in lower pyramids. In view of this policy and visionary decisions if taken democratically, or through an opinion poll, it bears a risk of irreversible damage. Moreover, long term decisions require that any new proposition is viewed critically and then given a fair opportunity to establish its credibility, before its wide spread implementation.

Leaders in any position, right from national to domestic level, must accept this challenge else they are fraught with risk of being rendered either ceremonial or infructuous. Every leader in a system has to integrate within it a work culture and processes, in a manner which are consistent and coherent with medium and long term vision, without ignoring immediate and short-term challenges. In every system leaders are vested with extraordinary and discretionary power. Exercise of such powers to handle contingencies requires honesty and sincere efforts. It is seen that some of them even are afraid of using ordinary powers.

A society or nation to sustain coherent and consistent growth needs to protect quality of environment, health and education. Environment is about being in livable conditions of air, water, food and shelter. Health is about surviving in a fully functional state of mind and body. At this stage emphasizing on education, which is implicit into maintenance of health and environment, would be over doing it.

As regards education, middle and upper class families are too obsessed with return on investment (ROI) in education of their children, and in turn they miss to emphasis upon the quality of education and resort to fake proxies of it viz. cost, marks, admissions, placement and pay-packets. This, in the first place, has driven this system to its present state of

commercial vulnerability. This truth is not a new discovery but, it is mostly ignored in a rat race. Eventually, whole system is eroding at its roots.

Despite, our claims of patriotism, best democracy and a golden bird, if there continues to be a breach of expectations and transformation, **is it not a tragedy?** If answer is “**yes**” then first victim of this **tragedy is education**, which flows like blood in society. It nurtures next generation. Despite, at system level education is construed to be non-productive and not of immediate consequence. This is the reason that teachers are the first to be called upon for assistance in any non-academic activity, at a cost of education. *This, however, does not absolve teachers from their basic responsibility of imparting quality education, without falling pray to systemic aberrations and commercial inclination in education.*

System has to be organically adaptable and focussed. *The OMS model is a voluntary initiative operating outside school hours so as to avoid to-and-fro intervention where schools maintain their curriculum, and **OMS focuses on mentoring concepts**.* This mission of GVS through OMS proposition is neither to read nor listen to praise but, an opportunity to collectively complement with तन और मन so as to reach target students. On the contrary, the moment it is requested to complement efforts, the responders suddenly takes a repulsive posture. **Why is the drift so abrupt?** Someone has said that “क्रान्तिकारी अथवा समाज-सुधारक/प्रवर्तक जब तक दुसरे के घर में है

तब तक वह सराहनीय है, परन्तु वह प्रवृत्ति मुझमें अथवा मेरे घर में कदापि नहीं “.

*With all these experiences in this initiative to democratize education with a sense of PSR, the only motivation is from famous verse of Gita “कर्मण्येवाधिकारस्ते मा फलेषु कदाचन...” and we are committed to it unto the last. In continuing this stream, it is hoped that MHRD, an apex body at system level, in a government which vouches for सबका साथ - सबका विकास, would provide an audience to explore “**why this model of OMS does deserves a fair trial?**” If it does not happen then this model is likely to get buried in debris of time. **We are open to any advice in respect of our aim, objective, vision and modus of operandi which makes it better, more selfless and purposeful.***

Contents of this article mask identities of individual or institution in the case studies. The aim is to put forth experiences of systemic and leadership issues with prejudice to none. It is, further, aimed at to arouse a concern of elite audience, who are positioned to make a difference, so that they can come out of an indifferent approach and *address need to remedy system aberrations with a sense of PSR which, otherwise, would eat away, like termite, remnant latent capacity of the system.*

*If this can be made to happen we all elite would have a solace that we are not leaving behind a legacy of a **tragic education system** to our descendents.*

—00—

I am impressed with the urgency of doing. Knowing is not enough, use it; being willing is not enough, do it.

-Leonardo da Vinci

A hundred times a day I remind myself that my inner and outer life are based on the labors of other men, living and dead, and that I must exert myself in order to give in the same measure as I have received and am still receiving.

-Albert Einstein

GROWING WITH CONCEPTS

Concepts of an expert are not like a static foundation of a huge structure; rather it is like blood flowing in a vibrant mind.

*During growing into an expert, each one must have used best of the books available on subject and received guidance of best of the teachers. Authors might have had limitations to take every concept thread bare from first principle and so also must be the constraint of teacher while mentoring a class with a diversity of inquisitiveness and focus. As a result, there are instances when on a certain concept a discomfort remains. The only remedy is to live with the conceptual problem and continue to visualize it thread bare till it goes to bottom of heart and that is an **ingenious illustration**.*

In this column an effort is being made to take one topic on Mathematics, Physics and Chemistry in each e-Bulletin and provide its illustration from First Principle. We invite all experts in these subjects to please mail us their ingenious illustrations and it would be our pleasure to include it in the column.

We hope this repository of ingenious illustrations, built over a period of time, would be helpful to ignite minds of children, particularly to aspiring unprivileged students, that we target in this initiative, and in general to all, as a free educational web resource.

This e-Bulletin covers – a) [Mathematics](#), b) [Physics](#), and c) [Chemistry](#). This is just a beginning in this direction. These articles are not replacement of text books and reference books. These books provide a large number of solved examples, problems and objective questions, necessary to make the concepts intuitive, a journey of educational enlightenment.

Looking forward, these articles are being integrated into Mentors' Manual. After completion of series of such articles on Physics it is contemplated to come up representative problems from contemporary text books and Question papers from various competitive examinations and a guide to their solutions in a structured manner, as a dynamic exercise to catalyse the conceptual thought process.

. —OO—

OUR MENTORING PHILOSOPHY: Mentoring is not teaching, neither tuition nor coaching. It is an activity driven by passion, and commerce has no place in it. In this effort is to caution students that -

- This place is not where they will be taught how to score marks and get higher ranks, but to conceptualize and visualize subject matter in their real life so that it becomes intuitive.
- This place is not to aim at solutions but inculcate competence to analyze a problem and evolve solution.
- This place does not extend selective and personalized attention, rather an opportunity to become a part of which is focused on learning and problem solving ability collectively.
- This place provides an opportunity to find students above and below one's own level of learning. Thus students develop not in isolation but learn from better ones and associate in problem solving to those who need help. This group dynamics while create a team spirit, an essential attribute of personality, while one learns more by teaching others.
- This place has strategically chosen Online Mentoring, so that those who are unprivileged can gather at one point and those who can facilitate learning of such students by creating, necessary IT setup. A separate [Mentor's Manual](#) is being developed to support the cause.

We are implementing this philosophy through [Online Mentoring](#)

Value of Patriotic Education

Aarti Sharma

- *A group of students from a reputed university gather to shout anti national slogans in the campus. Beating the drums they revel in shouting that country will be broken into pieces under the very roof of the government institution which aspires to serve motherland by achieving new heights of academic excellence.*
- *Tension between India and one of its hostile neighbors escalates due to unprovoked firing by the latter. However, members of film and art fraternity continue to support the actors of that country giving overwhelming preference to namesake art over their beloved motherland. Few of them shamelessly step far ahead and say that the country is not worth living blithely forgetting that their very own countrymen gave them so much popularity and a celebrity status.*
- *Pseudo intellectuals sitting in their cushy chambers question the veracity of sacrifice made by the bravest of brave Indian armed and police forces and instead lend their support to terrorists and insurgents who want to break the country from within and outside . Some even go a step forward and question the sacrifices of the revolutionary freedom fighters just because they did chose a path different from the others.*
- *Institutions, workplaces, organizations, offices continue to carry on their usual work without observing a minute of homage to the countless brave heart martyrs who fearlessly defended the borders of the motherland so that all the citizens could live peacefully.*

The above regretful instances point to downright thanklessness and ingratitude towards the beloved motherland in which this young intelligentsia, full of energy and potential, were brought up with lots of aspiration to do something positive for their nation. Instead of upholding the dignity and integrity of the nation they like to utter baseless anti national remarks at the flimsiest of reasons notwithstanding that they owe their lofty social ,educational, financial and myriad status to the their home land .

1 Why patriotism is amiss: Patriotism refers to devoted love, attachment and support towards one's motherland setting aside religious and regional differences and disparities. Patriotism is a feeling that inspires every citizen to contribute to their country and countrymen's growth and happiness in whatever way they can.

During the formative years, the youngsters take many things for granted be it freedom of expression, rights and privileges and are apathetic and near senseless towards problems and adversities faced by the country. They don't realize the immense sacrifices made by the valiant unsung heroes (whether military or civil) due to which they are able to breathe an air of freedom and peace away from the bondage of political, economic and religious slavery. Such instances occur due to lack of patriotism and nationalism for which a host of factors are responsible as discussed below.

a. Self centered and apathetic approach :
To uncover the apathetic attitude towards the

country an analysis of their formative years' nurturing is necessary. When young children enter the formal schooling system they are made to study concepts pertaining to different academic disciplines , memorize them, take tests and get graded based on the evaluation. This cycle is followed throughout the nineteen odd years of schooling life. Upon completion of schooling system, they enroll in different professional courses for career building and advancement. Throughout this long and winding process, nowhere are they taught about values and ideals that develop love and passion for the country.

Upon completion of this tedious study cycle, they look towards the country with a highly ambitious and expectant view as to what more and better it can give further. In fact, a majority of them become restive and impatient when their desires and wants are not met instantly or when even modest curbs or rules are placed on them to make them responsible and law abiding citizens.

Nowhere does it strike the students that being ably educated they should contribute to growth and development of the country by helping the socially and economically underprivileged class by sharing the fruits of learning that they attained during their school and college days.

b. Approach of Contemporary education system: Onus for lack of patriotism lies not

just on the indifferent attitude of the young generation but also the education system which did not give due importance and recognition to this fundamental concept while imparting knowledge about various concepts. In the name of knowledge the curriculum gives detailed account of the past and present events, rise and fall of empires and dynasties, etc. This bland narration is bereft of significant relevance in the context of building and unification of nation.

Our motherland has been a witness to numerous foreign invasions since centuries. The curriculum also falls short to highlight the contribution of the legendary warriors who courageously defended their kingdoms from foreign invaders and were able to uphold the native cultural and religious ethos of their motherland. Their bravery and valor is enough to motivate attachment and love amongst youngsters towards the country. There is also saga of great monarchs who not only ousted foreign invaders but made the foundations of strong and vibrant India. A classic instance in the point is the inspiring narrative of how Chandragupta Maurya under the able guidance of his Guru Chanakya defeated the strong army of Greeks led by Alexander the great with careful planning and built a powerful Mauryan empire and unified whole of India. Alongside, imparting of lessons from Arthshastra (an internationally acclaimed treatise on statecraft and economic policy composed by Chanakya) could be narrated in the class. Such inspirational study modules which can assuredly inculcate sense of pride and commitment towards the country are amiss in the current dispensation prevalent in the schools.

c. Degradation of traditional social, spiritual and moral values that made India a world leader : *“There are certain world-wanderers who ramble the earth, neither fixing their hearts on any country nor settling for even a month in any city. But when they arrive in the land of Hindustan, they abandon their wanderings and at last settle down.”*

These remarks by a poet Historian though are in the context of Ibn Batuta's (Famous 11th century Moroccan Traveller) love for India but apply universally to great travelers who came to India to quench their thirst of knowledge in various fields be it religion,

philosophy, governance, administration. Ancient and medieval India had a rich abundance of spiritual, moral and philosophical teachings propounded by great men like Gautam Buddha, Shankracharya, Mahaveer, Basvanna, Madhva charya, Namdev, Kabir, Guru Nanak that not only unified the whole nation into one fabric but also made it the global ambassador of tolerance, love, peace and universal brotherhood.

Many foreign scholars like Hueing Tsang, Fa hien greatly commended the administrative, social, religious and cultural condition of India. Hieung Tsang described Indians as lovers of education, literature and fine art who observed high morality in their social and personal lives. He profusely praised the tolerance among people of all religious faiths.

Marco Polo , the famous 11th century traveler drew a rich social portrait of India that still resonates today in his famous book, *The Travels*. He fondly documented an incident where upon entering the kingdom of the Tamil Pandyas (near modern Tanjore) he found that the king and his barons and everyone else sitting on the earth. When asked as to why they 'do not seat themselves more honorably.' The king replied, 'To sit on the earth is honorable enough, because we were made from the earth and to the earth we must return.'

India was also a great seat of learning. A variety of ancient higher-learning institutions were developed which provided institutional frameworks for scholarly activities. The oldest university in the world – Nalanda University was built in Maghada (now Bihar) . Ancient India had highly evolved technologies in engineering, weaponry, climatology and meteorology, architecture, medicine and surgery.

Unfortunately, this beautiful phase was overshadowed by centuries of foreign invasions and colonization that destroyed these rich seats of learning as well as several ancient texts of knowledge. There was a sharp degradation in the philosophical and cultural traditions of India as also dilution in value orientation among the people towards their motherland. The crass influence of foreign invaders and rulers divided our nation on economic, caste, ethnic and religious lines by shaking the rich spiritual and moral

foundations and also weakening, in the course, sense of nationalism and patriotism that Indians once proudly possessed.

2. Instilling patriotism: There is a strong requirement of developing an eco-system where students could learn and develop patriotism by stemming the causes as mentioned above. Educational Boards and institutions need to realize and frame a suitable policy to instill the values of patriotism among the young generation by building a foundation of love and attachment towards the motherland right from the very beginning i.e. the preprimary schooling stage. Curriculum content should be formulated according to appropriate age groups to inculcate and rejuvenate spirit of nationalism. A multipronged course of action in this context is enumerated below:-

a. Invoke the glorious past and present:

There is a need to unearth and profusely illustrate the wealth of knowledge of our ancestors that made Bharat (India) a *vishva guru* (world leader). The information about the science and technological heritage of India is embedded in the scriptures, the epics and in several of the technical texts. Sanskrit, our glorious ancient language, has been observed to be the most perfect and exquisitely refined language by western scholars. Many schools in European countries are teaching this ancient language due to its unique quality of direct linkage between sound and phonetics that make it easy flowing, natural and logical. Yoga is accepted world wide as a holistic well-being therapy and integrated in the school curriculums around the world. Similarly, there is a veritable goldmine of information from various fields of knowledge that is highly relevant and useful in today's modern world that needs to be taken out and disseminated in the classes to inculcate a spirit of pride and passion for the motherland.

b. Saga of legendary political and religious freedom warriors:

Our magnificent phases of history are full of legends of great men and women from distinguished fields of service be it administration, armed forces or any other who devotedly worked towards making our motherland free from shackles of economic, political, religious and social slavery. The heroic tales of these sons of soil hitherto lost into oblivion need to be ploughed out and given due recognition in the curriculum.

To illustrate some glorious instances of unparalleled valor, the martyrdom of four sons of tenth Sikh Guru Gobind Singh ji needs to be narrated as to how they bravely sacrificed their lives to protect the religious freedom. Their brave ethos stand immortalized in the annals of history as the cause for which they gave up their lives echo in the fundamental right to freedom of religion that is granted to citizens by the constitution of India. Martyrdom of foursome Chapekar brothers hailing from Pune who fought against the British mismanagement and oppression also deserves a distinct mention. Several unsung heroes died in cellular jail (Andaman and Nikobar islands) due to atrocities and torture of the British Government. Their sufferings and sacrifices need to be put forth before the young generation who are breathing an air free from slavery and bondage.

Shifting some more pages of history one can find awe inspiring bravery and fearlessness of Hari Singh Nalwa commander in chief of Maharaja Ranjit Singh's army who killed a tiger bare handedly earning the nickname of *baaghmar* (tiger killer). His valorous tales need to be integral part of curriculum to ignite passion to serve the motherland. He stands ennobled for defending the motherland from ruthless Afghan invaders and ably serving as governor of many provinces. Students need to be particularly explained about the fear that he stoked in the hearts of the enemy as also his brave military conquests. These and many other glorious instances can create a diehard fervor towards motherland among the young generation.

c. Bravery tales of Indian armed forces heroes:

A detailed account of various wars fought after the independence of India and the gallant tales of countless bravest of brave men belonging to the Indian armed forces needs to be a permanent fixture in the curriculum. This aspect of the curriculum needs to be updated regularly, if possible. There should be a regular Newspaper / chronicle session in the classroom where instances of bravery and valour of the armed forces can be read out and their importance narrated to the students. Plays, dramas and skits on these brave men can also be enacted to motivate the students. Inspired by the valor and the heroism, the students would automatically develop a sense of commitment and service to the nation which is

presently found lacking. There should be compulsory enrolment into NCC and NSS camps at different age levels to inculcate spirit of service towards the nation.

d. Shining instances from leadership and public service: Our nation became strong and powerful not just with the mighty armed forces but also with the untiring and selfless efforts made by great men and women from distinguished fields of service. Role of Visionary and great leaders in making India self reliant and powerful; and providing a dominant stature in the comity of the nations need to narrated in this context so that students can draw inspiration from them.

They should also be explained about the notable role of the distinguished civil services and their devoted and untiring commitment in ensuring the welfare and growth of the people of India. Be it implementation of the welfare schemes or ensuring law and order or representing our country at various international forums or functioning as a watchdog public funds along with giving valuable recommendations for improving efficiency of operations and many other spheres of public service, their illustrious services to the nation needs to be applauded and demonstrated as a role model for the students.

Similarly, inventions of many scientists and social entrepreneurs that spearheaded eradication of hunger and poverty post independence and made our country self sufficient in the food grains productions. Noteworthy instances that need to be elucidated to the students include father of green revolution MS Swaminathan renowned for his leading role in India's Green Revolution a program under which high-yield varieties of wheat and rice made our nation not only self sufficient in food grains production but net exporter of food grains . Youth can also take pride in Father of milk revolution, Verghese Kurien whose dairy development programme, Operation flood made India the world's largest milk producer in the world . The humble story of Missile man and People's President APJ Abdul Kalam Azad also needs to be lauded and narrated to the students for his pioneering achievements in India's civilian space and mission development programme. Lessons from the life of Bindeshwar Pathak (founder of sulabh

international) in spreading the mission of sanitation and waste management needs to told to students to create awareness and sensitization towards this hygiene and cleanliness . Such inspiring instances from public life would motivate students to do something constructive and worthy for the nation.

e. Instill a sense of respect for law of the land: It is seen that young generation is a little off hand when it comes to observance of extant rules and regulations and respecting laws of the land. Whether it is compliance of traffic laws, environment laws, tax laws or any other etc. there is general perception of nonchalance and apathy. There is an urgent need to correct their flawed perspective. The youth should be made aware that law is a form of social control, a mechanism used by the government agencies to regulate the activities of all individuals within any society and nation. Basically, all laws are meant for the betterment of the society. They need to be apprised about the importance of various laws in the context of nation building and consequential inseparability exist between the two. Hence, respect and compliance of laws is a must for every citizen so as to prevent spread of anarchy and disorder thereby enabling peace and prosperity of the nation

f. Encourage to become a good citizen: The general atmosphere at school has a major impact on the young impressionable minds of the students as they spend a great deal of their time there. It is therefore the duty of the schools to acquaint the students about the significance of being good citizen in overall well-being and steady progress of the nation. They should balance academics with character development especially community oriented character, knowledge and strengths to prepare them to become good and active citizens. Teachers should plan out daily lessons to ingrain observance of civic duties, display of good character, being respectful and helpful towards members of the community, among the students in order to be an ideal citizen. They should be apprised about the importance of their individual or collective efforts as citizens in laying the foundation of a strong nation.

g. One India one nation: The richness and divergence of our cultures, religion and ethos should be a matter of pride and achievement among the young generation as no other country in the world can boast of such heterogeneity as our country has. However, it is quite often seen that students from cosmopolitan India mock at ethnic origins, racial features and languages of those hailing from other parts of the India. They need to be sensitized that plurality and diversity is the foundation of our country and that men and women from all races, religion and region are equal in the eyes of the constitution of India and deserve same privileges and rights as those staying in cosmopolitan India do.

Conclusion - Impact of patriotic education:
Patriotic education can be reckoned as key driver for

igniting the passion in the young generation to work for the development of the country with sincerity and earnestness. With its core objectives of building values, awareness, knowledge and skills among the children it naturally fosters love for the motherland, motivates to help in solving socio economic problems as also in the due discharge of the fundamental duties. The personal qualities and behavioral attributes developed in the due course help the children to become good citizens and prevent the emigration of the skilled youth, who otherwise see lack of opportunities and growth for themselves in their own country. By instilling a sense of love for motherland, patriotic education is able to achieve the mission of preparing the young generation to serve the motherland to the best of the capabilities, whatever may be the constraints.



Author is Senior Audit Officer working with the office of Comptroller & Auditor General of India. She is a regular writer on issues of diverse nature having impact on education, health, environment, and social psychology and dynamics. **E-mail ID:** aartiissar04@gmail.com

—00—

INVITATION FOR CONTRIBUTION OF ARTICLES

*Your contribution in the form of an article, story poem or a narration of real life experience is of immense value to our students, the target audience, and elite readers of this Quarterly monthly e-Bulletin **Gyan-Vigyan Sarita: शिक्षा**, and thus create a visibility of the concerns of this initiative. It gives them a feel that you care for them, and they are anxiously awaiting to read your contributions. We request you to please feel free to send your creation, by **20th of this month** to enable us to incorporate your contribution in next bulletin, subhashjoshi2107@gmail.com.*

We will be pleased have your association in taking forward path our plans as under-

- **2nd Supplementary e- Bulletin of 4th Quarterly e-Bulletin Gyan-Vigyan Sarita: शिक्षा shall be brought out 1st September'17. It shall be dedicated to Teachers' Day to commemerate the occasion on 5th September.**
- **And this cycle monthly supplement to Quarterly e-Bulletin Gyan-Vigyan Sarita: शिक्षा aimed to continue endlessly**

We believe that this monthly supplements to quarterly periodicity of e-Bulletins shall make it possible for our esteemed contributors to make contribution rich in content, diversity and based on their ground level work.

—00—

SETS, FUNCTIONS, AND RELATIONS

Prof. SB DHAR

Set

Set is defined as a collection of well-defined objects.

It is represented in two forms:

- (a) **Roster Form:** In this way of representation, all the elements are represented in List form. For example, if one is collecting vowels of English Alphabet, it will be written as $\{a, e, i, o, u\}$. The order of elements does not matter in writing the set.
- (b) **Set builder Form:** In this way of expressing the set, we choose a property among all the elements that is common and single property and is not possessed by any element outside the set. For example: The set of vowels of English Alphabet is written as $\{x: x \text{ is a vowel of English Alphabet}\}$

Note:

- (a) Absolute properties do not form sets.

For example: We cannot collect the intelligent persons. We cannot have the set of beautiful or handsome persons. The reason behind this is simple: no one can decide the parameter of these virtues.

- (b) A set does not change if one or more elements of it are repeated.
- (c) Georg Cantor (1845-1918) is considered the originator of the modern set theory.
- (d) The set is always represented through **braces** $\{\}$. It is also called the curly brackets.
- (e) The things written in curly brackets are called **elements** of the set.

Important Terminology

Cardinal Number: It is the number of elements in a finite Set. The number of elements means the distinct elements in the set.

- (a) Cardinal number of a Power Set $= 2^n$ if the number of elements in the set is n .
- (b) If cardinal number of set A is n , then total number of subsets of $P(A) = 2^{2^n}$ and the total number of proper subsets $= 2^{2^n} - 1$. $P(A)$ represents the **power set of A**.

Comparable Sets: Two sets A and B are said to be comparable if $A \subset B$ or $B \subset A$ or $A=B$, otherwise they are called incomparable sets.

Empty Set: The set that contains no element is called an empty set. It is denoted by $\phi = \{ \}$.

- (a) $\{0\}$ or $\{\phi\}$ is not an empty set.
- (b) Empty set is also called the **Null set** or the **Void set**.
- (c) Empty set is a finite set.

Singleton set: It is a set that contains only one element.

For example: $\{2\}$, $\{a\}$.

The set whose cardinal number is 1, is called a singleton set.

Finite Set: Finite set is a set that contains countable number of elements. For example: $A = \{1, 2, 3, 4, 5, 6\}$

The set whose cardinal number is a whole number, is called finite set.

Infinite Set: Infinite set is a set that contains uncountable number of elements. For example: $N = \{1, 2, 3, \dots\}$, set of Natural numbers because there is no end of the elements of this set i.e. there is no largest natural number in this set.

Equal Sets: Equal sets are the sets that contains the same elements. For example: $A = \{1, 2, 3, 4\}$ and $B = \{2, 4, 1, 3\}$. A and B are equal as their elements are same.

Equivalent Sets: Equivalent sets are the sets whose cardinal numbers are same but the elements may differ. For example:

$A = \{a, b, c, d, e\}$ and $B = \{1, 2, 3, 4, 5\}$. Both the sets have 5 elements but their elements are different, hence A and B are equivalent sets.

Note:

Equal sets are always equivalent but vice-versa not true.

Subset: Sub set is a set that has at least one element less than its super set (main set). The number of subsets in a finite set A, whose cardinal number is n is 2^n . This is also the number of distinct subsets of A.

Note:

- (a) Every non-empty set has two improper subsets.
- (b) Proper subset is the set that has lesser cardinal number than its superset. The number of proper subsets in a finite set of cardinal number n is $2^n - 2$.
- (c) The null set has only one subset (i.e. null set itself) that is improper.
- (d) Improper subsets are null set and the set itself.

Power Set: Power set is the set of all possible subsets of the set.

Note:

- (a) Set itself and the empty set are the members of this set.
- (b) If $A \subseteq B$ then $P(A) \subseteq P(B)$.
- (c) $P(A \cap B) = P(A) \cap P(B)$, and $P(A) \cup P(B) \subseteq P(A \cup B)$.

Universal Set : Universal set is the set that is the superset of all sets.

Note:

Universal sets differ as the point of reference differ. For example: the super set of all students of a city may differ from the super set of all students of other city. Super set of reading materials may differ from the super set of kitchen materials.

Union of Sets: Union of sets A and B is given by $A \cup B = \{x : x \in A \text{ or } x \in B\}$.

Note:

$$x \notin (A \cup B) \Rightarrow x \notin A \text{ and } x \notin B.$$

Intersection of Sets: Intersection of sets A and B is given by $A \cap B = \{x : x \in A \text{ and } x \in B\}$.

Note:

- (a) $x \notin (A \cap B) \Rightarrow x \notin A \text{ or } x \notin B$
- (b) $n(A \cup B) = n(A) + n(B) - n(A \cap B)$

Disjoint Sets: Disjoint sets are the sets that have no common elements i.e., $(A \cap B) = \phi$.

For example:

- (a) The set of positive integers Z^+ and set of negative integers Z^- have no common elements, hence they are disjoint sets.
- (b) A family of various sets is called pairwise disjoint if no two members of its family have a common element.

For example:

If $A_1, A_2, A_3, \dots, A_n$ are pairwise disjoint then $A_1 \cap A_2 \cap A_3 \cap \dots \cap A_n = \phi$. But if $A_1 \cap A_2 \cap A_3 \cap \dots \cap A_n = \phi$, then $A_1, A_2, A_3, \dots, A_n$ may not be pairwise disjoint.

- (c) If $A_1, A_2, A_3, \dots, A_n$ are pairwise disjoint sets then $n(A_1 \cup A_2 \cup A_3 \cup \dots \cup A_n) = n(A_1) + n(A_2) + n(A_3) + \dots + n(A_n)$.

Difference of two sets: Difference of two sets A and B is given by $A - B = \{x : x \in A \text{ and } x \notin B\}$.

Symmetric difference of two sets: Symmetric difference of two sets A and B is given by $(A - B) \cup (B - A)$. It is denoted by $A \Delta B$.

Complement of a set: Complement of a set is given by $A' = U - A$, that is, set of all elements of the Universal set other than the elements of set A.

Note:

- (a) Complement is the difference with Universal set.

- (b) Complement of Universal set is an Empty set and vice-versa i.e. $(U)' = \phi$ and $(\phi)' = U$.
- (c) Complement of a complement is the set itself i.e. $(A')' = A$.

Idempotent Law:

- (a) $A \cup A = A$
 (b) $A \cap A = A$

Identity Law:

- (a) $A \cup \phi = A$
 (b) $A \cap U = A$

Commutative Law :

- (a) $A \cup B = B \cup A$
 (b) $A \cap B = B \cap A$

Associative Law :

- (a) $A \cup (B \cap C) = (A \cup B) \cap C$
 (b) $A \cap (B \cup C) = (A \cap B) \cup C$

Distributive Law :

- (a) $A \cup (B \cap C) = (A \cup B) \cap (A \cup C)$
 (b) $A \cap (B \cup C) = (A \cap B) \cup (A \cap C)$

De-Morgan Law :

- (a) $(A \cup B)' = A' \cap B'$
 (b) $(A \cap B)' = A' \cup B'$

Ordered pair: The ordered pairs are said to be equal if and only if the corresponding first elements are equal and the second elements are also equal.

For example:

- (a) $(a, b) \neq (b, a)$
 (b) $(a, b) = (c, d)$ iff $a = c$ and $b = d$

Cartesian product of two sets: Cartesian Product of two sets A and B is given by $A \times B =$ Set of all ordered pairs starting from A to B = $\{ (a, b): a \in A \text{ and } b \in B \}$.

- (a) Graph of $A \times B$ represents points on the Cartesian plane.
- (b) The number of elements in the Cartesian Product = $n(A) \cdot n(B)$
- (c) If either of A or B is an infinite set then $A \times B$ is also an infinite set.
- (d) $n(A \times B) = n(A) \cdot n(B)$ and $n(P(A \times B)) = 2^{n(A) \cdot n(B)}$.
- (e) If A and B are two non-empty sets having n elements common then $A \times B$ and $B \times A$ have n^2 elements common.
- (f) If $A = \phi$ or $B = \phi$ then $A \times B = \phi$.
- (g) If at least one of the A and B is infinite set then $A \times B$ is also an infinite set provided that the other is non-empty set.
- (h) $A \times A \times A = \{ (a, b, c): a, b, c \in A \}$. (a, b, c) is called an ordered triplet. It represents points in 3-D space.

Regarding Number of elements:

- (a) Number of elements belonging to *exactly one of the sets A, B and C* = $n(A) + n(B) + n(C) - 2n(A \cap B) - 2n(B \cap C) - 2n(C \cap A) + 3n(A \cap B \cap C)$
- (b) Number of elements belonging to *exactly two of the sets A, B and C* = $n(A \cap B) + n(B \cap C) + n(C \cap A) - 3n(A \cap B \cap C)$
- (c) Number of elements belonging to *at least two of the sets A, B and C* = $n(A \cap B) + n(B \cap C) + n(C \cap A) - 2n(A \cap B \cap C)$
- (d) Number of elements belonging to *at most two of the sets A, B and C* = $n(A \cup B \cup C) - n(A \cap B \cap C)$

Sets containing:

- (a) *Only A occurs* out of A, B and C $(A \cap \bar{B} \cap \bar{C})$
- (b) *Both A and B, but not C occurs* $(A \cap B \cap \bar{C})$
- (c) *All the three occur* $(A \cap B \cap C)$
- (d) *At least one occurs* $(A \cup B \cup C)$
- (e) *At least two occur* $(A \cap B) \cup (B \cap C) \cup (A \cap C)$

- (f) *One and no more occur*
 $(A \cap \bar{B} \cap \bar{C}) \cup (\bar{A} \cap B \cap \bar{C}) \cup (\bar{A} \cap \bar{B} \cap C)$
- (g) *Exactly two of A, B and C occur*
 $(A \cap B \cap \bar{C}) \cup (\bar{A} \cap B \cap C) \cup (A \cap \bar{B} \cap C)$
- (h) *None occurs* $(\bar{A} \cap \bar{B} \cap \bar{C}) = \overline{A \cup B \cup C}$
- (i) *Not more than two occurs*
 $(A \cap B) \cup (B \cap C) \cup (A \cap C) - (A \cap B \cap C)$
- (j) *Exactly one of A and B occurs* $(A \cap \bar{B}) \cup (\bar{A} \cap B)$

Notes:

- (a) Some of the infinite sets cannot be expressed in the Roster form or Listing form.
 For example:
 The set of Real Numbers cannot be written in Roster form as there are always an infinite number of real numbers between any two numbers.
- (b) The real numbers are very well depicted on a Real Number Line.
- (c) The Real Numbers are also expressible in forms of Intervals: Closed Interval [3,5], Open Interval (3,5), Open-Closed Interval (3,5] and the Closed-Open Interval [3,5).
- (d) Closed Interval [3,5] means $\{x: 3 \leq x \leq 5\}$
- (e) Open Interval (3,5) means $\{x: 3 < x < 5\}$
- (f) Open-Closed Interval means $\{x: 3 < x \leq 5\}$
- (g) Closed-Open Interval means $\{x: 3 \leq x < 5\}$

Relation:

If A and B are two non-empty sets then *a relation from A to B* is defined as *a subset of A × B*. This subset may be an empty as well as A × B.

If (a,b) belongs to R, then a is related to b, and written as a R b. If (a,b) does not belong to R then it is written as a \nR b.

Note:

- (a) The set of all first element of the ordered pairs in a relation R from a set A to set B is called the domain of the relation R and the second element of ordered pair is called the range. The whole set B is called the codomain of the relation R.
- (b) Range \subseteq Codomain (always)

Types of Relations

Void Relation: A relation R in a set A is called an Empty relation, if no element of A is related to any element of A, i.e. $R = \phi \subset A \times A$. Empty set is called the void relation as it is a subset of $A \times A$.

Universal Relation: A relation R in a set A is called universal relation, if each element of A is related to every element of A, i.e. $R = A \times A$. $A \times A$ is called the Universal relation.

The Empty Relation: R on a non-empty set X (i.e. a R b is never true) is not an equivalence relation, because although it is vacuously symmetric and transitive, it is not reflexive (except when X is also empty)

Identity Relation: Consider a set $A = \{1,2,3\}$. Identity relation of set A from A to A is given by $I_A = \{(1,1), (2,2), (3,3)\}$.

Every Identity relation is reflexive but every reflexive relation need not be an Identity relation, i.e., Reflexive relation has always some more elements than an Identity relation.

Inverse Relation: $R^{-1} = \{(1,3), (2,4), (5,6)\}$ is said to be inverse relation of $R = \{(3,1), (4,2), (6,5)\}$.

The domain of R becomes the range of R^{-1} and vice-versa.

Reflexive Relation: If all the elements of A are related to itself, then the relation is said to be reflexive.

For example:

If $A = \{1,2,3\}$ then the relation $R_1 = \{(1,1), (2,2), (3,3)\}$ is a reflexive relation or $R_2 = \{(1,1), (2,2), (3,3), (1,2), (1,3)\}$ is

reflexive relation but $R_3 = \{(1,1), (2,2)\}$ is not a reflexive relation as $(3,3)$ is not therein.

Note:

- (a) *A reflexive relation on A is not necessarily the identity relation on A.*
- (b) *The Universal relation on a non-void set A is reflexive.*
- (c) The cardinal number of Reflexive relations 2^A where A is the number of elements in set A.

Symmetric Relation: If $(x,y) \in R \Rightarrow (y,x) \in R$. **R is symmetric if and only if $R^{-1} = R$.**

Note:

- (a) *The Identity and the Universal relations on a non-void set are symmetric relations.*
- (b) *A reflexive relation on a set A is not necessarily symmetric.*

Transitive Relation: R is called a transitive relation if and only if $(a,b) \in R, (b,c) \in R \Rightarrow (a,c) \in R$.

Equivalence Relation: A relation R in a set A is said to be an **equivalence relation** if R is reflexive, symmetric and transitive.

Ordered Relation

R is called to be an ordered relation if it is transitive but not equivalence relation.

Partial Ordered Relation

R is called a Partial Ordered relation if it is reflexive, transitive but not symmetric relation.

Note:

- (a) If R is reflexive, then R^{-1} is also reflexive.
- (b) If R is symmetric, then R^{-1} is also symmetric.
- (c) If R is transitive, then R^{-1} is also transitive.

(d) If R is an equivalence relation, then R^{-1} is also an equivalence relation.

(e) Total **number of relations** from A to B is the number of possible subsets of $A \times B$. If $n(A) = p$ and $n(B) = q$ then total number of relations = 2^{pq} as each subset of $A \times B$ defines relation from A to B.

(f) Among the total number of relations 2^{pq} , the void relation ϕ and the universal relation $A \times B$ are trivial relations from A to B.

Equivalence Class [a] : Let R be an equivalence relation in A (non-empty set). Let $a \in X$. Then the equivalence class of a, (denoted by [a]) is defined as the set of all those points of A that are related to a under the relation R.

It is expressed as $[a] = \{x \in A : x R a\}$.

Note:

- (a) $b \in [a] \Rightarrow a \in [b]$
- (b) $b \in [a] \Rightarrow [a] = [b]$
- (c) *Two equivalence classes are either disjoint or identical.*

Congruence Modulo (m) :

Let m be an arbitrary but fixed integer. Two integers a and b are said to be congruence modulo m if a-b is divisible by m. It is written as

$$a \equiv b \pmod{m}.$$

i.e. $a \equiv b \pmod{m} \Leftrightarrow a-b$ is divisible by m.

For example:

$$18 \equiv 3 \pmod{5} \text{ as } 18-3 \text{ is divisible by } 5.$$

$$\text{Also, } 5 \equiv 10 \pmod{5} \text{ as } 5-10 \text{ is divisible by } 5.$$

Note:

The relation “congruence modulo m” is an equivalence relation.

Composition of Relations : Let R and S be two relations from sets A to B and B to C respectively.

Then the relation SoR from A to C such that $(a,c) \in SoR \Leftrightarrow \exists b \in B$ such that $(a,b) \in R$ and $(b,c) \in S$. This relation is called the composition of R and S .

In general $RoS \neq SoR$.

Also if SoR exists then RoS may not exist. But $(SoR)^{-1} = R^{-1} \circ S^{-1}$.

Remembering Facts

- Let A and B be two non-empty sets having n elements common, then $A \times B$ and $B \times A$ will have n^2 elements common.
- The universal relation on a set A containing at least 2 elements is not anti-symmetric, because if $a \neq b$ are in A , then a is related to b and b is related to a under the universal relation will imply that $a=b$ but $a \neq b$.
- The set $D = \{(a,a) : a \in A\}$ is called the diagonal line of $A \times A$. The relation R in set A is anti-symmetric iff $R \cap R^{-1} \subseteq D$.
- The relation "is congruent to" on the set T of all triangles in a plane is a transitive relation.
- The union of two equivalence relations on a set is not necessarily an equivalence relation on the set.
- If a set contains $2n+1$ elements. Then the number of subsets of this set that contains more than n elements is equal to 2^{2n} .

Function

A RELATION from set A to set B is called a function if every element of set A has one and only one image in set B .

In other words, a function f is a relation from a non-empty set A to a non-empty set B such that the domain of f is A and no two distinct ordered pairs in f have the same first element.

Or,

If a perpendicular dropped on the axis of X , cuts the curve at **one** point only, then the graph represents a function *otherwise not*.

Note:

The word "function" was introduced into Mathematics by Leibniz, who used this term primarily to refer to certain kinds of Mathematical Formulas. It was later realized that Leibniz's idea of *function* was much too limited in its scope, and the meaning of the word has since undergone many stages of generalization.

Number of Functions : If $n(A)=a$ and $n(B)=b$ then **total number of functions** from A to $B = b^a$.

- Total **number of one-one functions** from A to $B = {}^b P_a$ if $b \geq a$ otherwise it is 0 where $n(A)=a$ and $n(B)=b$.
- Total **number of Onto function** s (surjections) from A to $B = \sum_{r=1}^b (-1)^{b-r} \cdot {}^b C_r \cdot r^a$
- The **number of Onto functions** defined from a finite set A containing a elements onto a finite set B containing 2 elements = $2^a - 2$.
- Total **number of one-one onto** (bijection) from A to $B = a!$ or $b!$ (factorial a or factorial b) as the number of elements in $A =$ number of elements in B .

Special Functions

One-one function or Injective function : A function $f : X \rightarrow Y$ is defined to be **one-one** (or **injective**) if for every $x_1, x_2 \in X$, $f(x_1) = f(x_2) \Rightarrow x_1 = x_2$. Otherwise, f is called many-one.

Onto Function or Surjective: A function $f : X \rightarrow Y$ is said to be **onto** (or **surjective**) if for every $y \in Y$, there exists an element x in X such that $f(x) = y$.

One-one onto or Bijective : A function $f : X \rightarrow Y$ is said to be **one-one** and **onto** (or **bijective**), if f is both one-one and onto.

Remembering Facts

- For an **onto function range = co domain**.

- (b) A one- one function defined from a finite set to itself is always onto but if the set is infinite then it is not the case.
- (c) Linear polynomial functions $(ax+b)$, x , e^x , $\log x$ are always one-one function.
- (d) If $(dy/dx) > 0$, or, $(dy/dx) < 0$, then $y=f(x)$ is one-one, iff f is a continuous function.
- (e) All even functions, modulus functions, periodic functions are always many-one functions.
- (f) Square functions and Trigonometric functions are many-one functions in their domain.
- (g) $\sin\sqrt{x}$ and $\sin x^2$ are not periodic as they cannot be expressed in $f(x+T)=f(x)$.

Composite Functions : If $f : A \rightarrow B$ and $g : B \rightarrow C$ are two functions, then the **composition** of f and g , denoted by gof , is defined as the function $gof : A \rightarrow C$ given by $gof(x) = g(f(x))$, $\forall x \in A$.

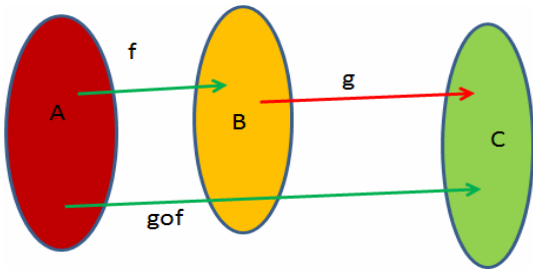

Composition of f and g is written as gof and not fog .
 gof is defined if the range of $f \subseteq$ domain of g and fog is defined if range of $g \subseteq$ domain of f .

Remembering Facts:

- (a) A function $f : X \rightarrow Y$ is defined to be **invertible**, if there exists a function $g : Y \rightarrow X$ such that $gof = I_X$ and $fog = I_Y$. The function g is called the inverse of f and is denoted by f^{-1}
- (b) If f is invertible, then f must be one-one and onto and conversely, if f is one-one and onto, then f must be invertible.

- (c) In general fog and gof are not equal, i.e. composition of functions is not commutative but it is associative. i.e. if $f : X \rightarrow Y$, $g : Y \rightarrow Z$, and $h : Z \rightarrow S$ then $h \circ (g \circ f) = (h \circ g) \circ f$
- (d) If either of the two f and g , one is an Identity function then, fog and gof are identity functions.
- (e) If $f : A \rightarrow B$ and $g : B \rightarrow C$ are one-one and onto then $gof : A \rightarrow C$ is also one-one and onto. But if gof is one-one then only f is one-one g may or may not be one-one. If gof is onto then g is onto, f may or may not be onto.
- (f) Given a finite set X , a function $f : X \rightarrow X$ is one-one (respectively onto) if and only if f is onto (respectively one-one). This is the characteristic property of a finite set. This is not true for infinite set.
- (g) Let $f : X \rightarrow Y$ and $g : Y \rightarrow Z$ be two invertible functions. Then gof is also invertible with $(gof)^{-1} = f^{-1} \circ g^{-1}$.

Facts Related to the Domain and the Range:

- (a) The set of values taken by X is called the **domain** and is denoted by D_f and the set of values taken by Y is called the **range** and is denoted by R_f .
- (b) Domain of $y = f(x) \pm g(x)$ or $f(x).g(x)$ or $f(x)/g(x)$ is given by $D_1 \cap D_2$ or $D_1 \cap D_2 - \{g(x)=0\}$.
- (c) Domain of **absolute value of function** or **Modulus function**, $y = |x|$ is $(-\infty, \infty)$.
- (d) Domain of **exponential function** $f(x) = a^x$, $a > 0$ and $a \neq 1$ is set of Real Number.
- (e) Domain of **logarithmic function** $f(x) = \log_a x$; ($x, a > 0$) and $a \neq 1$ is all real positive numbers.
- (f) If $f(x)=c$ for all $c \in X$, and Y is singleton set of c , $f : X \rightarrow Y$ is called the **constant function**.
- (g) If $f(x)=x$ for all $x \in X$, $f : X \rightarrow Y$ is called the **identity function**.

- (h) If $f(x) = x^a$ for $a \in \mathbb{R}$, then $f: \mathbb{R} \rightarrow \mathbb{R}$ is called the **Power function**.
- (i) Absolute value function is also called modulus function or **numerical value function**. It is defined as $|x| = +x$ if $x > 0$ and $|x| = -x$ if $x < 0$
- (j) **Signum function** $y = \text{sgn}(x) = |x|/x$.
- (k) Domain of signum function is \mathbb{R} .
- (l) The **greatest integer function**: it is also called the **step up function**. It is written as $f(x) = [x]$. It means $f(0) = [0] = 0$, $f(3/2) = [3/2] = 1$, $f(-1/2) = [-1/2] = -1$. It consists of two parts: integral part and the fractional part. The fractional part is always greater than or equal to zero but less than 1. It is also denoted as $f(x) = [x] = x + \{x\}$.

The Fractional Part Function

- (a) $\{x\} = x$, if $0 \leq x < 1$ and 0 if $x \in \mathbb{Z}$.
- (b) $\{-x\} = -1 - \{x\}$ if $x \notin \mathbb{Z}$.

Exponential Function: Exponential function is defined as $f(x) = a^x$. It increases if $x > 0$ and decreases if $x < 0$.

Logarithmic Function : Logarithmic function is defined as $f(x) = \log_a x$. It is defined only when $a > 0$, it is not defined when $a \leq 0$. It increases if $a > 1$ and decreases if $0 < a < 1$.

Even function : If $f(-x) = f(x)$ for all x .

Odd function: If $f(-x) = -f(x)$ for all x .

Facts relating to EVEN and ODD functions

- (x) The product of two even or two odd functions is always even function.
- (y) The product of even and odd is always an odd function.
- (z) Every function can be expressed as the sum of an even and an odd function. for example:

$$f(x) = \frac{1}{2}(f(x) + f(-x)) + \frac{1}{2}(f(x) - f(-x))$$

Periodic Function: A function $f(x)$ is said to be periodic if there exists such an $T > 0$ for which $f(x+T) = f(x-T) = f(x)$ for all $x \in X$. note: there are infinitely many T satisfying the equality but the least positive is said to be the period.

Period of $\sin x, \cos x, \text{cosec} x, \sec x = 2\pi$ and the period of $\tan x, \cot x = \pi$,

Monotonic Functions : Monotonic functions are defined on interval.

These are of nature: monotonic increasing if for all $x_1, x_2 \in [a, b]$ and $x_1 < x_2$ there exists $f(x_1) \leq f(x_2)$.

Note:

- (a) Monotonic decreasing if for all $x_1, x_2 \in [a, b]$ and $x_1 < x_2$ there exists $f(x_1) \geq f(x_2)$.
- (b) Strictly monotonic increasing if for all $x_1, x_2 \in [a, b]$ and $x_1 < x_2$ there exists $f(x_1) < f(x_2)$.
- (c) Strictly monotonic decreasing if for all $x_1, x_2 \in [a, b]$ and $x_1 < x_2$ there exists $f(x_1) > f(x_2)$.

Special type of function:

Dirichlet function

$$\lambda(x) = \begin{cases} 1, & \text{if } x \text{ is rational} \\ 0, & \text{if } x \text{ is irrational.} \end{cases}$$

It is discontinuous at each point.

Example:

$$\lambda(0) = 1$$

$$\lambda(-1/2) = 1$$

$$\lambda(\sqrt{2}) = 0$$

$$\lambda(\pi) = 0$$

Facts to Remember for Solving Questions:

(a) If $f(x)$ is polynomial function satisfying $f(x)f\left(\frac{1}{x}\right) = f(x) + f\left(\frac{1}{x}\right)$ then the function

should be assumed as $f(x) = 1 \pm x^n$

(b) $(x-1) < [x] \leq x$, $2x-1 < [2x] \leq 2x$.

(c) $\left[\frac{n+1}{2}\right] + \left[\frac{n+2}{4}\right] + \left[\frac{n+4}{8}\right] + \left[\frac{n+8}{16}\right] + \dots = n, n \in N$.

(d) $[x] + \left[x + \frac{1}{n}\right] + \left[x + \frac{2}{n}\right] + \left[x + \frac{3}{n}\right] + \dots = [nx], n \in N$.

The Factorial Function: This is defined as $f(n) = n! = 1.2.3 \dots n$ for all positive integers.

The domain of this function is the set of positive integers.

The function value (Range) increases so rapidly that it is more convenient to display this function in tabular form rather than as a graph. This is listed as the pairs $(n, n!)$.

Equal Functions : Two functions f and g are equal if and only if

f and g have the same domain, and $f(x) = g(x)$ for every x in the domain.

Linear Function : A function f defined for all real x by a formula of the form $f(x) = ax + b$, is called a linear function because its graph is a straight line.

Lattice Point : A point (x, y) in the plane is called a *lattice point* if both the co-ordinates x and y are integers.

BINARY OPERATION

A **binary operation** $*$ on a set A is a function $*$: $A \times A \rightarrow A$. Notation: $*$ (a, b) by $a * b$.

Facts:

(a) Given a binary operation $*$: $A \times A \rightarrow A$, an element $e \in A$, if it exists, is called **identity** for the operation $*$, if $a * e = a = e * a, \forall a \in A$. Identity element is unique.

(b) An element $a \in X$ is invertible for binary operation $*$: $X \times X \rightarrow X$, if there exists $b \in X$ such that $a * b = e$

$= b * a$ where, e is the identity for the binary operation $*$, then the element b is called **inverse of a** and is denoted by a^{-1} .

(c) An operation $*$ on X is **commutative** if $a * b = b * a \forall a, b$ in X .

(d) An operation $*$ on X is **associative** if $(a * b) * c = a * (b * c) \forall a, b, c$ in X .

(e) If the operation table is symmetric about the diagonal line then, the operation is commutative.

(f) Addition $(+)$ and multiplication $(.)$ on N , the set of natural numbers are binary operations. But subtraction $(-)$ and division (\div) are not since $(4,5) = 4-5 = -1$ does not belong to N and $(4 \div 5)$ also does not belong to N .

(g) Binary operations are functions.

Number of Binary Operations : Number of binary operations on $A =$ Number of functions from $A \times A$ to $A = A^{A \times A}$, where A represents the Cardinal Number of the Set A . For example: if the cardinal number of A is 3 then the number of binary operations $= 3^{3 \times 3} = 3^9$.

Solved Questions

1. If $f: R \rightarrow R$ and $g: R \rightarrow R$ are defined by $f(x) = 2x+3$, and $g(x) = x^2 + 7$, then find the values of x such that $g(f(x)) = 8$.

Solution:

$$g(f(x)) = g(2x+3) = (2x+3)^2 + 7 = 8 \text{ (given).}$$

$$\text{Therefore, } 4x^2 + 12x + 8 = 0$$

$$\text{Or, } x^2 + 3x + 2 = 0$$

$$\text{Or, } x = -1, -2$$

2. If $f: R \rightarrow R$, and $g: R \rightarrow R$ are given by $f(x) = \lfloor x \rfloor$ and $g(x) = [x]$ for each $x \in R$, then find $\{x \in R : g(f(x)) \in f(g(x))\}$.

Solution:

$$g(f(x))=g(|x|)= [|x|]$$

$$f(g(x))=f(|x|)= [|x|]$$

Two cases may arise

- (i) $x \geq 0$, i.e. $[|x|] = [x] = [|x|]$ i.e. $f(g(x))=g(f(x))$
- (ii) $x < 0$, i.e. $[x] \leq x < 0$ i.e. $[|x|] \geq |x|$ i.e. $[|x|] \geq |x| \geq [x]$
as $[x] \leq x$ for all x $f(g(x)) \geq g(f(x))$ for all $x \in \mathbb{R}$.

3. Let $f: [-2,2] \rightarrow \mathbb{R}$ be defined by

$$f(x) = -1, \text{ for } -2 \leq x \leq 0$$

$$=x-1, \text{ } 0 \leq x \leq 2$$

Then find $\{x \in [-2,2]: x \leq 0 \text{ and } f(x) = x\}$

Solution:

Obviously,

$$f(-1)=-1, f(1)=0, f(0)=-1, f(|-1/2|)=f(1/2)=1/2 -1=-1/2$$

Then the required result is $\{-1/2\}$

4. If $e^{f(x)} = \frac{10+x}{10-x}, x \in (-10,10)$ and $f(x) = k \left(\frac{200x}{100+x^2} \right)$

then find value of k

Solution:

Using the definition of logarithm

$$x^y = z \Rightarrow \log_x z = y$$

Let us write the given expression as below:

$$f(x) = \log_e \frac{10+x}{10-x}$$

Also write $f\left(\frac{200x}{100+x^2}\right)$ using the above definition of the

$$\text{function as : } = \log_e \frac{10 + \frac{200x}{100+x^2}}{10 - \frac{200x}{100+x^2}}$$

$$= 2 f(x)$$

$$\text{i.e. } f(x) = (1/2) f\left(\frac{200x}{100+x^2}\right)$$

Hence

$$k = 1/2$$

5. If x, y, z are positive real numbers, then find the relation

$$\text{between } x, y, z \text{ when } \frac{x^3}{z} < \frac{x^3 + y^3 + z^3}{x + y + z} < \frac{z^3}{x}$$

Solution:

Out of many possible cases, assume

$$\text{If } x < y < z \text{ then } x^3 < y^3 < z^3$$

Or,

$$2x < x + y < 2z, 2x^3 < x^3 + y^3 < 2z^3$$

Or

$$3x < x + y + z < 3z, 3x^3 < x^3 + y^3 + z^3 < 3z^3$$

Or

$$(1/3x) > 1/(x+y+z) > (1/3z), \text{ under the above condition}$$

Or

$$(1/3z) < 1/(x+y+z) < (1/3x), \text{ under the above condition}$$

Or

$$3x^3/(3z) < (x^3 + y^3 + z^3)/(x+y+z) < 3z^3/(3x)$$

6. Find the number of reflexive relations of a set with 3 elements.

Hint: The number of reflexive relations on an n -element set is 2^{n^2-n} .

7. If $A = \{(x, y): x^2 + y^2 = 25\}$ and $B = \{(x, y): x^2 + 9y^2 = 144\}$ then evaluate $A \cap B$.

Hint: Note $A \cap B$ means the points of intersection of the two curves. Obviously it is 4.

8. Let A_1, A_2, \dots, A_{30} be thirty sets each containing five elements and B_1, B_2, \dots, B_n are n sets each with three elements such that $\bigcup_{i=1}^{30} A_i = \bigcup_{i=1}^n B_i, A_i \cap A_j = S$. If each element of S belongs to exactly ten of the A_i 's and exactly 9 of the a_j 's, then find the value of n .

Hint:

Each of A_i has 5 elements, hence $\sum_{i=1}^{30} n(A_i) = 5 \cdot 30 = 150 = 10m$

(as each element of S belongs to exactly 10 of A_i 's if S has m distinct elements). i.e. $m=15$.

Similarly, B_j has 3 elements, hence $\sum_{j=1}^{30} n(B_j) = 3n = 9m$ i.e. $n=45$

9. A set contains $(2n+1)$ elements. Find the number of subsets of this set containing more than n elements.

Solution:

The required number = ${}^{2n+1}C_{n+1} + {}^{2n+1}C_{n+2} + \dots + {}^{2n+1}C_{2n+1} = (1/2)(2^{2n+1})$ by use of binomial theorem.

10. A survey shows that 63% people like cheese, 76% like apples. If $x\%$ like both cheese and apples, then find the value of x .

Solution:

Obviously, $n(C)=63, n(A)=76, n(C \cap A)=x$.

Use: $n(C \cup A) = n(C) + n(A) - n(C \cap A) \dots$ (i)

And $n(C \cup A) \leq 100 \dots$ (ii)

i.e. $n(C) + n(A) - n(C \cap A) \leq 100$

$\Rightarrow 63 + 76 - x \leq 100$

$\Rightarrow x \geq 39$

And $n(C \cap A) \leq n(C)$

$\Rightarrow x \leq 63$

$\Rightarrow 39 \leq x \leq 63$

11. Let A be a non-empty set and let $*$ be a binary operation on $P(A)$, the Power set of A defined by $X * Y = (X - Y) \cup (Y - X)$ for $X, Y \in P(A)$. Show that

(i) ϕ is the identity element for $*$ on $P(A)$.

(ii) X is invertible for all $X \in P(A)$ and $X = X^{-1}$.

Solution:

For any $X \in P(A)$,

$X * \phi = (X - \phi) \cup (\phi - X)$ by definition.

$= X \cup \phi = X$

Similarly,

$\phi * X = X$

$\Rightarrow X * \phi = \phi * X = X, \forall X \in P(A)$

$\Rightarrow \phi$ is an Identity element in $P(A)$ for binary operation $*$ on $P(A)$.

Also, for any $X \in P(A)$, evaluate that

$X * X = \phi$ by definition

\Rightarrow every element X of $P(A)$ is invertible and is inverse of itself.

12. If A is finite, then find the number of distinct subsets of A .

Hint:

Number of distinct subsets = ${}^nC_0 + {}^nC_1 + {}^nC_2 + \dots + {}^nC_n = 2^n$

13. Two finite sets A and B have m and n elements. Number of subsets of A is 56 more than that of B . Evaluate the values of m and n .

Hint:

Obviously, $2^m = 56 + 2^n$.

By trial, $m=6$ and $n=3$

14. Let $P = \{(x, y): y = a^x, x \in \mathbb{R}\}$, $Q = \{(x, y): y = \log_a x, x > 0\}$ and $0 < a < 1$ then find the cardinal number of the set of solutions of P and Q .

Hint:

Obviously, both the graphs $y=a^x$ and $y=\log_a x$ are the reciprocal of each other that intersect at only one point. Hence number of solutions=1.

15. If two sets A and B are having 99 elements in common, then find the number of elements common to each of the sets $A \times B$ and $B \times A$.

Hint:

The required number = 99^2

16. On the power set P of a non-empty set A , an operation Δ is defined as $X \Delta Y = (X \cap Y^c) \cup (X^c \cap Y)$. Then show

that for (P, Δ) , it is commutative and associative with an identity.

Solution:

Δ is obviously, symmetric difference i.e.

$$X \Delta Y = (X - Y) \cup (Y - X)$$

And

$$X - Y = X \cap Y^c$$

Δ is commutative, associative and ϕ is an identity element for this operator.

$$A \Delta \phi = (A - \phi) \cup (\phi - A) = A \cup \phi = A \text{ for all } A \in P.$$

17. If B is the set of numbers obtained by adding 1 to each of the even numbers, then write it in its set builder form.

Solution:

$$B = \{t+1: t = 2n, n \in \mathbb{Z}\} = \{2n+1, n \in \mathbb{Z}\} = \{x : x \text{ is odd and } x \in \mathbb{Z}\}$$



Dr S.B. Dhar, is **Editor of this Quarterly e-Bulletin**. He is an eminent mentor, analyst and connoisseur of Mathematics from IIT for preparing aspirants of Competitive Examinations for Services & Admissions to different streams of study at Undergraduate and Graduate levels using formal methods of teaching shared with technological aids to keep learning at par with escalating standards of scholars and learners. He has authored numerous books – Handbook of Mathematics for IIT JEE, A Textbook on Engineering Mathematics, Reasoning Ability, Lateral Wisdom, Progress in Mathematics (series for Beginner to Class VIII), Target PSA (series for class VI to class XII) and many more.
e-Mail ID: maths.iitk@gmail.com

—00—

***First they will ignore you,
then they laugh at you,
then they fight you,
then you win (truth follows...)***

- Mahatma Gandhi

CROSSWORD PUZZLE Aug'17: SET THEORY

Prof. SB. Dhar

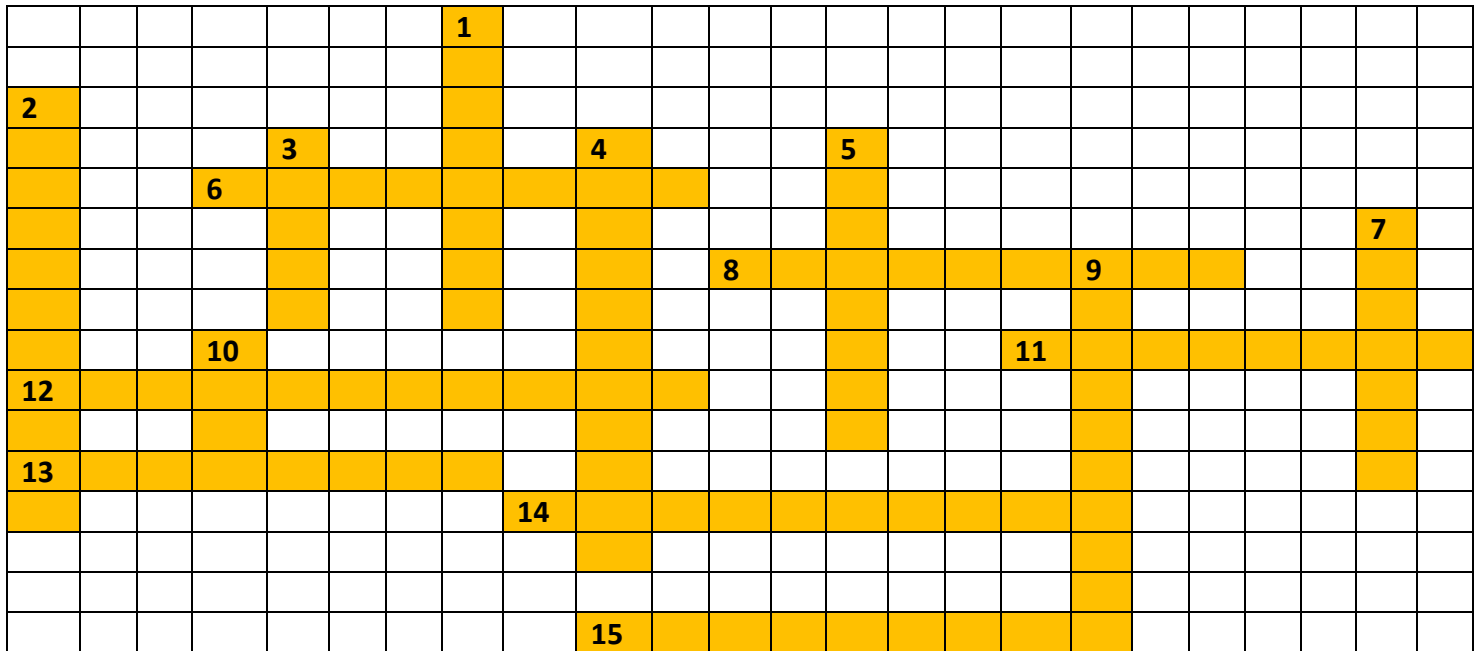

ACROSS

- 6 Set of all possible subsets
- 8 Name of One-one-onto function
- 11 Mathematician who introduced “function”
- 12 Name of function like $f(x)=a^x$
- 13 Term for number of elements in a set
- 14 Difference with universal set
- 15 Function that is 0 at irrational and 1 at all rational numbers

DOWN

- 1 Form in which real number sets are expressed
- 2 Name of congruence modulo relation
- 3 Name of function like $f(x)=x^a$
- 4 Originator of Set Theory
- 5 Sets having no common elements
- 7 Name of Point whose both co-ordinates are integers
- 9 Law for $A \cup A = A$
- 10 Set that contains no element

(Answer to this Crossword Puzzle shall be provided in Supplementary e-Bulletin Dt. 1st Sept'17)

GROWING WITH CONCEPTS: Physics

ELECTROMAGNETISM – Part III: Alternating Current and Circuits

Alternating Current has an interesting history of conflict of concepts and convictions between Two great inventors **Nikola Tesla** and **Thomson Edison**, who were earlier colleagues,. An international exhibition at Germany, in 1891, where effectiveness of AC in handling power a long distance was demonstrated, Edison was convinced on merits of AC. This event marked **End of War of Currents**, and it paved away for further research and development. In present times, despite merits of AC to provide portability and handling of power, there is a threshold beyond which transmission of power in DC mode is preferred. This is an excellent example of theory of Evolution by **Karl Marx – Thesis ->Antithesis –> Synthesis, which in turn becomes Thesis and cycle continues**. As one proceeds corroboration of qualitative aspects and analytical inferences become increasingly important, and that makes the journey thrilling and purposeful. This chapter covers only basics of AC Circuits within the scope of this manual. Nevertheless, readers inquisitive to know details of AC and DC electrical systems are welcome to write through [Contact Us](#).

Alternating Current: Basics of generator in Electromagnetics, Part-II of Current Electricity, where conversion of mechanical energy into electrical energy has been elaborated. Alternating Current has a specific amplitude vs. time variation called sinusoidal waveform, called characteristic waveform, and its generation is at core of AC systems. A coil having N turns if rotates at an angular velocity $\omega = \frac{d\theta}{dt}$ in a uniform magnetic field, its flux linkage changes from $(+)N\Phi A$ to $(-)N\Phi A$ and this cycle continues with a periodicity $T = \frac{1}{f} = \frac{2\pi}{\omega}$. Thus according to Faraday-Lenz's Law instantaneous EMF induced in the coil would be, $E_t = -\frac{d\psi}{dt} = -\frac{d(N\vec{B}\cdot\vec{A})}{dt} = -\frac{d(NBA \cos \theta)}{dt} = -NBA \frac{d(\cos \theta)}{dt}$, since, number of turns (N), Flux Density (B) being uniform and Area (A), decided by

geometry of coil are constant, and hence magnitude of voltage would vary with instantaneous angular position of the coil would be $E_t = NBA \sin \theta \frac{d\theta}{dt} = V_{max} \sin \omega t$. Here, $V_{max} = NBA\omega$, **Maximum Value of the instantaneous emf or voltage**. This variation of magnitude of voltage at different angular positions of the coil is shown in the figure, for Five discrete positions, with the corresponding graph for continuous variation of voltage w.r.t. time. Accordingly variation of current depending upon characteristic of load, that shall be elaborated a little later. *It is to be noted that unlike DC there are no (+)ve or (-)ve terminals. Both the terminals attain (+)V and (-) V voltages alternately as shown in the figure, and drive current in the circuit. Accordingly, it is called Alternating Current.*

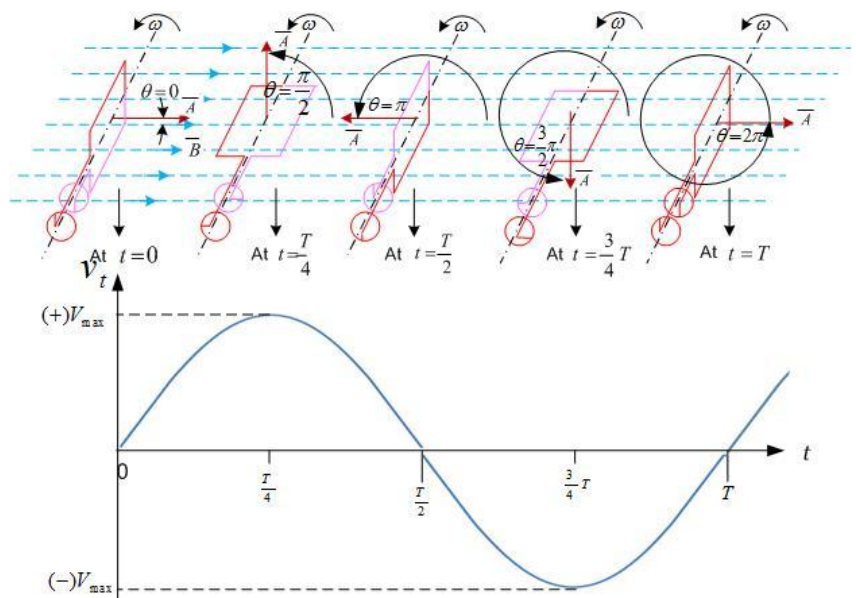
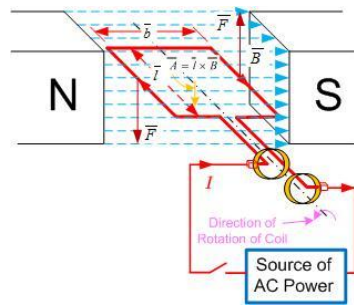

Parametric Quantities of an AC waveform: An AC waveform has Three parametric quantities – **a)** Maximum Value, **b)** Average Value, **c)** Effective Value, and **d)** Form Factor, each of them is being elaborated. **Maximum Value** is peak of value (unsigned) of the electrical quantity, be it voltage or current, and is important from the point of maximum mechanical stress that can occur in use of an electrical device. This is pertinent from the point of Ampere's Force Law, which stipulates, dependence of force between two current

carrying conductors on the magnitude of the current. Qualitatively average value of voltage, as visible from the waveform over complete cycle is Zero, nevertheless, it is defined over half-time period of the cycle from $t = 0 \rightarrow \theta = 0$ to $t = \frac{T}{2} \rightarrow \theta = \pi$ and mathematically **Average Value** $V_{av} = \frac{\int_0^\pi V_{max} \sin \theta d\theta}{\pi} = \frac{V_{max}[-\cos \theta]_0^\pi}{\pi} = \frac{V_{max}}{\pi/2}$.

DC measuring instruments, which are not based on the principle of power content of electrical quantity are capable of measuring Average Value. Concept of **Effective Value** comes from heating effect, which as per definition of electrical power is proportional to square of the voltage or current and, therefore, effect of signed value of the electrical quantity vanishes over complete cycle. Accordingly, can be taken over any period, $t \rightarrow \theta$ to $t = t + \frac{T}{2} \rightarrow \theta = \theta + \pi$. Therefore, mathematically, $V_{eff}^2 = \frac{1}{\pi} \int_\theta^{\theta+\pi} (V_{max} \sin \theta)^2 d\theta = \frac{V_{max}^2}{\pi} \int_\theta^{\theta+\pi} \sin^2 \theta d\theta = \frac{V_{max}^2}{2\pi} \int_\theta^{\theta+\pi} (1 - \cos 2\theta) d\theta$. On integration it leads to $V_{eff}^2 = \frac{V_{max}^2}{2\pi} \left[\theta - \frac{\sin 2\theta}{2} \right]_\theta^{\theta+\pi} = \frac{V_{max}^2}{2}$, or $V_{eff} = \frac{V_{max}}{\sqrt{2}}$, and it leads to eventually it is square-root of mean of the square of the electrical quantity and hence, this **Effective Value** is also called **Root Mean Square (RMS) Value** of the voltage or current. **Concept of rms value of voltage and current would become more explicit, a little later, when voltage, current and power of AC circuits is elaborated.** Ratio of RMS value and average value of an electrical quantity, is called **Form Factor (FF)** and is representative of degree of distortion of actual waveform of electrical voltage and current from Sinusoidal waveform. *Form Factor for sinusoidal waveform is $FF = \frac{V_{rms}}{V_{av}} = \frac{V_{max}/\sqrt{2}}{V_{max}/\pi/2} = \frac{\pi}{2\sqrt{2}} = 1.11$, and it changes on distortion in waveform.* Readers inquisitive to know details of AC and DC electrical systems are welcome to write through [Contact Us](#).

AC Circuits: These are classified into – **a)** VR circuit having a sinusoidal voltage source connected across resistance only, **b)** VR circuit having a sinusoidal voltage source connected across inductance only, **c)** VR circuit having a sinusoidal voltage source connected across capacitance only, and **d)** VR circuit having a sinusoidal voltage source connected across combination of resistance, inductance and capacitance, there three electrical elements in turn can be in series, parallel and hybrid formations.

VR Circuit: A circuit having an AC source ($v_t = V \sin \omega t \rightarrow v_\theta = V \sin \theta$) with a resistance R connected across it through a switch, as shown in the figure. In this analysis, transients in electrical circuits during switching-in/off of circuit are ignored and steady-state condition, when current waveform has stabilized have been considered. Instantaneous voltage across resistance, as per Ohm's Law shall be $v_\theta = i_\theta R$. As per Kirchhoff's Voltage Law (KVL) $V \sin \omega t - i_t R = 0 \rightarrow V \sin \theta = i_\theta R$, therefore, current through resistance (R) shall be $i_\theta = \frac{V}{R} \sin \theta$. Thus current shall follow the same waveform as that of voltage with 0^+ crossing at the same instance, with a difference only in magnitude which is decided by $\frac{V}{R}$. Thus it is seen that value of resistance (R) remains unchanged. These voltage and current waveforms are called to be in-phase, as elaborated in Waves and Motion chapter.

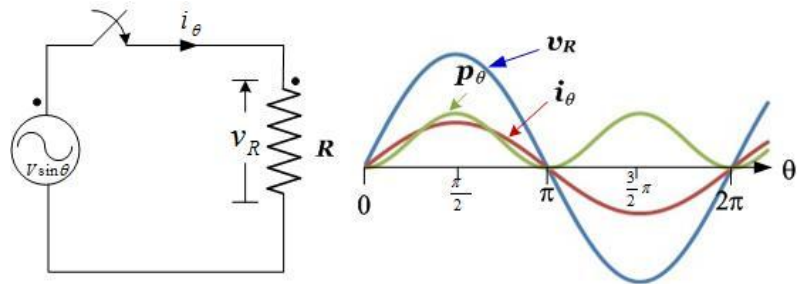

Instantaneous power in the **VR circuit** is $p_\theta = v_\theta i_\theta = (V \sin \theta) \left(\frac{V}{R} \sin \theta \right) = \frac{V^2}{R} \sin^2 \theta$. Thus **average power** utilized by the resistance works out to be $P = \frac{1}{2\pi} \cdot \frac{V^2}{R} \int_0^{2\pi} \sin^2 \theta d\theta = \frac{V^2}{2\pi R} \int_0^{2\pi} \frac{1}{2} (1 - \cos 2\theta) d\theta$. On integration it leads to $\frac{V^2}{4\pi R} \left[\theta - \frac{\sin 2\theta}{2} \right]_0^{2\pi} = \frac{V^2}{4\pi R} \cdot 2\pi = \frac{V^2}{2R} = \frac{V}{\sqrt{2}} \cdot \frac{V}{\sqrt{2} R}$. This is evident from the waveform of p_θ which is on (+)ve over the complete cycle. It leads to **$P = V_{rms} \cdot I_{rms}$** . **Thus effective power of a resistive circuit is product of rms values of voltage and current.** This is analogues to power equation of DC circuit where instead of V_{DC} and I_{DC} , values used are V_{rms} and I_{rms} , respectively.

Voltage and current in AC circuit can also be represented as vectors as shown in the figure, accordingly for in-phase current across resistor, it complies with power equal to dot product of Voltage and Current, analog of Force and Displacement, respectively. Thus, $P = \bar{V}_{rms} \cdot \bar{I}_{rms} = (V_{rms} \angle \theta_v) \cdot (I_{rms} \angle \theta_i) = V_{rms} I_{rms} \cos(\theta_v - \theta_i)$. It leads to $P = V_{rms} I_{rms} |_{\theta_v = \theta_i}$.

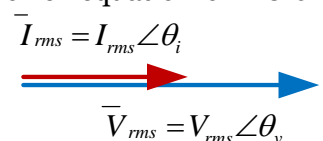

V-L Circuit: Analysis of V-L circuit in AC with a voltage source ($v_t = V \sin \omega t$) is identical to that of VR circuit

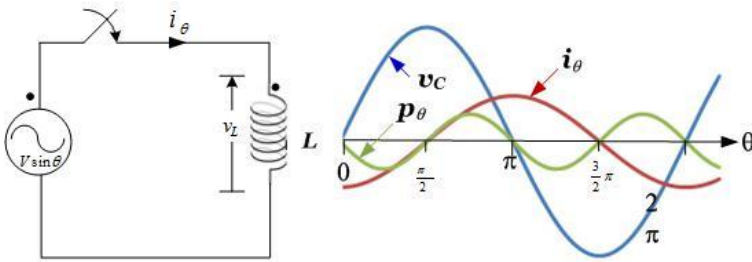

except that voltage equation, as per KVL, takes a different form due to inductive element (L). Voltage drop across inductance and Faraday-Lenz's Law $v_L = L \frac{di}{dt}$, and this absorbs (-)ve sign since it is voltage drop which tends to oppose the current through it, and accordingly as per KVL, $v_t - L \frac{di_t}{dt} = 0$. Accordingly, the equation becomes $\frac{di_t}{dt} = \frac{V}{L} \sin \omega t \rightarrow i_t = \frac{V}{L} \int \sin \omega t d\theta = -\frac{V}{\omega L} \cos \omega t$. It

leads to $i_t = \frac{V}{\omega L} \sin \left(\omega t - \frac{\pi}{2} \right) = \frac{V}{X_L} \sin \left(\omega t - \frac{\pi}{2} \right) \Big|_{X_L = \omega L}$. It leads to Three inferences – **a) current waveforms lags behind the voltage waveform by an angle $\frac{\pi}{2}$ radians ($=90^\circ$), or conversely voltage leading current by an angle 90° , called **Phase Angle** of current w.r.t. voltage in VL circuit, **b) instead of resistance (R) another factor Inductive Impedance ($X_L = \omega L$) comes into play.** In this, L is dependent on geometric and magnetic properties of the **Inductance**, while $\omega (= 2\pi f)$, depends upon frequency of the AC voltage, **c) Impedance of inductor is directly proportional to the frequency.****

Instantaneous power in the **V-L circuit** is $p_t = v_t i_t = (V \sin \omega t) \left(\frac{V}{X_L} \sin \left(\omega t - \frac{\pi}{2} \right) \right) = \frac{V^2}{X_L} \sin \omega t \cos \omega t$. Thus **average power** utilized by the inductance works out to be $P = \frac{1}{2\pi} \cdot \frac{V^2}{X_L} \int_0^T \sin 2\omega t dt = \frac{V^2}{4\pi R} [\cos 2\omega t]_0^T = 0$. It

leads to a conclusion that, though instantaneous power of an inductor is not Zero, but power consumption by an inductor over a cycle is Zero. This is evident from the waveform of instantaneous power (p_θ), which

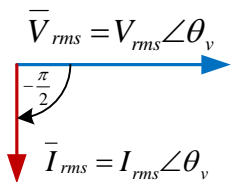

completes one cycle during a period $\frac{T}{2} = \pi$, leading to the above analytical conclusion. A qualitative justification for Zero power of inductor is that inductor exchanges energy stored in the form of magnetic field alternately with the source. Nevertheless, **since current is drawn by the inductor, product of V_{rms} and I_{rms} is called Apparent Power $P_{app} (= V_{rms} \cdot I_{rms})$.**

Representing voltage and current vectors in V-L circuit, analogous to that in V-R circuit, current vector is shown in figure lagging, the voltage vector, by a phase

difference of $\frac{\pi}{2}$, in accordance with the above stated analytical inference. Accordingly, power being equal to dot product of Voltage and Current vectors $P = \bar{V}_{rms} \cdot \bar{I}_{rms} = (V_{rms} \angle \theta_v) \cdot (I_{rms} \angle \theta_i)$. It leads to $P = V_{rms} I_{rms} \cos \left(\frac{\pi}{2} \right) \Big|_{\theta_v - \theta_i = \frac{\pi}{2}} = 0$.

V-C Circuit: Analysis of V-C circuit in AC is identical to that of V-L, circuit except that voltage equation, as KVL, is in context of capacitive element (C). Voltage across capacitor $v_c = v_\theta = \frac{q_\theta}{C}$ and as per KVL $V \sin \theta - v_c = 0 \rightarrow V \sin \theta = \frac{q_\theta}{C}$. In differentiating w.r.t. t it leads to $(\omega C) V \cos \theta = i_\theta$ since $i_\theta = \frac{d}{dt} q_\theta$. It

$i_\theta = \frac{V}{\frac{1}{\omega C}} \sin \left(\theta + \frac{\pi}{2} \right) = \frac{V}{X_C} \sin \left(\theta + \frac{\pi}{2} \right) \Big|_{X_C = \frac{1}{\omega C}}$. In time

domain the equation becomes $i_t = \frac{V}{X_C} \sin \left(\omega t + \frac{\pi}{2} \right)$. It

leads to Three inferences – **a) current waveforms leads the voltage waveform by an angle $\frac{\pi}{2}$ radians ($=90^\circ$), or conversely voltage lagging current by an angle 90° , called **Phase Angle** of current w.r.t. voltage in VL circuit, **b) Like inductive impedance, in case of capacitor another factor called Capacitive Impedance ($X_C = \frac{1}{\omega C}$) comes into play.** In this, C is dependent on geometric and magnetic properties of the **Capacitance**, while $\omega \rightarrow f$, depends upon frequency of the AC voltage, **c) Impedance of capacitor is inversely proportional to the frequency.****

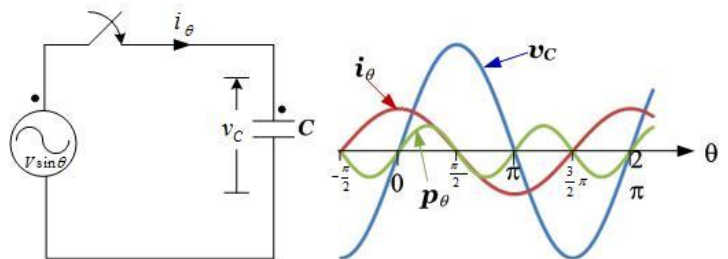

Instantaneous power in the **V-C circuit** is $p_t = v_t i_t = (V \sin \omega t) \left(\frac{V}{X_C} \sin \left(\omega t + \frac{\pi}{2} \right) \right) = \frac{V^2}{X_L} \sin \omega t \cos \omega t$. Thus **average power** utilized by the capacitance works out to be $P = \frac{1}{2\pi} \cdot \frac{V^2}{X_L} \int_0^T \sin 2\omega t dt = \frac{V^2}{4\pi R} [\cos 2\omega t]_0^T = 0$, and is equivalent to that derived for inductor. It leads to similar conclusion that, though instantaneous power of an capacitor is not Zero, but power consumption by an capacitor over a cycle is Zero. Capacitors exchanges energy stored in the form of electric field is alternately with the source. This is evident from the waveform of instantaneous power (p_θ), which completes one cycle during a period $\frac{T}{2} = \pi$, leading to the above analytical conclusion.

Since, **phase difference** between current with respect to voltage is $(+)$ $\frac{\pi}{2}$, while in inductor it is $(-)$ $\frac{\pi}{2}$, the instantaneous power waveforms in inductor and capacitor are anti-phase. This can be observed by comparing waveforms of p_t of V-L and V-C circuits shown above. Thus it forms an interesting case of having Resistance (R), Inductance (L) and Capacitance (C) in varying proportions i.e. RLC circuit, generally encountered in AC circuits, and shall be elaborated a little later.

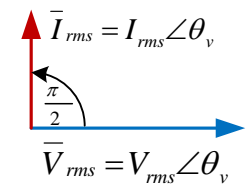

Representing voltage and current vectors in V-C circuit, on the lines of V-L circuit, current vector is, shown in figure, leading the voltage vector by a phase difference of $\frac{\pi}{2}$, in accordance with the above stated analytical inference. Accordingly, power being equal to dot product of Voltage and Current vectors $P = \bar{V}_{rms} \cdot \bar{I}_{rms} = (V_{rms} \angle \theta_v) \cdot (I_{rms} \angle \theta_i) = V_{rms} I_{rms} \cos \left(\frac{\pi}{2} \right) \Big|_{\theta_v - \theta_i = \frac{\pi}{2}} = 0$.

V-RLC Circuit: In this all the three elements, resistance, inductance and capacitance are there, in various formations. Initially, a simplest case of series combination of the three elements is shown in figure, for analysis. In elaboration of V-L and V-C circuit current lagging or leading voltage, respectively, or conversely voltage leading or lagging current, respectively was stated. Relevance of this statement shall become explicit in forgoing analysis.

In series combination of V-RLC current flowing through each element, in vector form, is $\bar{I} = I \angle \theta_i$, accordingly

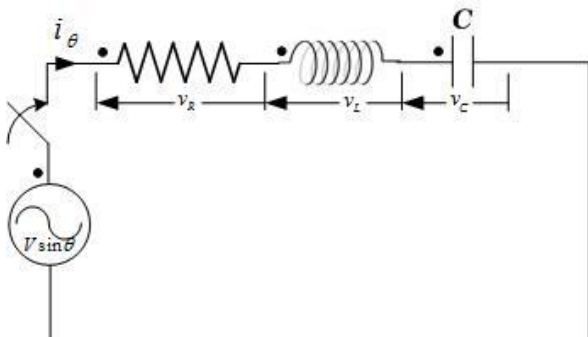

voltage across resistance (R) shall be $\bar{V}_R = \bar{I}R$, $\bar{V}_R = (I \angle \theta_i)R \angle 0 = IR \angle \theta_i$, and is in accordance with the inference in VR circuit. Likewise, vectorially, voltage across inductance (L) is $\bar{V}_L = (I \angle \theta_i) \left(\omega L \angle \frac{\pi}{2} \right) = IX_L \angle \left(\theta_i + \frac{\pi}{2} \right)$, this too is in conformity of phase-difference between current and voltage in VL circuit. Similarly, voltage across capacitance (C) is $\bar{V}_C = (I \angle \theta_i) \left(\frac{1}{\omega C} \angle -\frac{\pi}{2} \right)$. Or, $\bar{V}_C = IX_C \angle \left(\theta_i - \frac{\pi}{2} \right)$, this too goes along with the inference of phase-difference between current and

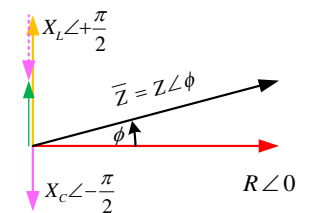

voltage in VL circuit. This analytical resemblance with inference brought out in individual circuit would not have been possible without considering $R \angle 0$ as reference vector and inductance and capacitance as vectors leading $(X_L \angle +\frac{\pi}{2})$ and lagging $(X_C \angle -\frac{\pi}{2})$ w.r.t reference vector. Thus, source voltage vector \bar{V} , as per KVL,

eventually shall be $\bar{V} = \bar{V}_R + \bar{V}_L + \bar{V}_C$. It leads to $\bar{V} = \bar{V}_R = IR \angle \theta_i + IX_L \angle \left(\theta_i + \frac{\pi}{2} \right) + IX_C \angle \left(\theta_i - \frac{\pi}{2} \right) = I \angle \theta_i Z \angle \phi$.

Here, magnitude of total impedance of RLC series combination is $Z = \sqrt{R^2 + (X_L - X_C)^2}$, and phase-angle $\phi = \tan^{-1} \left(\frac{X_L - X_C}{R} \right)$ a complex quantity $\bar{Z} = R + j(X_L - X_C)$. It is to be noted that in analysis of AC circuits

while representing of complex quantity j is used instead of $i = \sqrt{-1}$ as in algebra. This difference is attributed to electrical nature of inductance and capacitance drawing current lagging or leading by an angle $\frac{\pi}{2}$, elaborated above, and not the algebraic meaning, despite mathematical resemblance between them. Thus complex form of electrical quantities is conceptually different from complex numbers, despite identical mathematical treatment. This facilitates representation of complex value of electrical element in Cartesian and exponential form and for resistance it is

$\bar{R} = R + j0 = Re^{j0}$, for inductance it is $\bar{X}_L = 0 + jX_L = X_L e^{j\frac{\pi}{2}}$, for capacitance $\bar{X}_C = 0 - jX_C = X_C e^{-j\frac{\pi}{2}}$ and for total impedance of the series combination it is $\bar{Z} = R + j(X_L - X_C) = Ze^{j\phi}$. Accordingly, for determination of phase-angle of current vector $I \angle \theta_i$ in reference to source voltage $\bar{V} = V \angle 0$ is by simple division of complex quantities and it is $I \angle \theta_i = \frac{\bar{V}}{\bar{Z}} = \frac{Ve^{j0}}{Ze^{j\phi}} = \frac{V}{Z} e^{-j\phi}$. Conversely, if voltage vector is $V \angle \theta_v$, then current vector is $I \angle \theta_i = \frac{\bar{V}}{\bar{Z}} = \frac{Ve^{j\theta_v}}{Ze^{j\phi}} = \frac{V}{Z} e^{-j\phi}$. Thus magnitude of current $I = \frac{V}{Z}$. In this case $\theta_i = \theta_v - \phi$, and power drawn by the circuit $p = \bar{V} \cdot \bar{I} = VI \cos \phi$. This angle ϕ is called **Impedance Angle** and also as **Power Factor** of the circuit. This is also expressed as simple product of complex voltage and current as $p = \bar{V} \bar{I}^* \equiv \bar{V} \cdot \bar{I}$, here, voltage is $\bar{V} = Ve^{j\theta_v}$ and **Conjugate Current** $\bar{I}^* = Ie^{-j\theta_i}$, is taken instead of current ($\bar{I} = Ie^{j\theta_i}$), for mathematical validity.

This case of RLC combination leads to three situations **a)** Total Resistive Impedance or Load occurs when $X_L = X_C$. Since impedances X_L and X_C electrically out of phase, they cancel each other and $Z \angle \phi = R \angle 0$ and therefore power factor of load is Unity ($\cos 0 = 1$), i.e. $\phi = 0$ **b)** Inductive Load, when $X_L > X_C$ and this case inductance is partially cancelled by capacitance and $Z \angle \phi = \sqrt{R^2 + (X_L - X_C)^2} \angle \tan^{-1} \frac{X_L - X_C}{R}$, where $\phi = \tan^{-1} \frac{X_L - X_C}{R}$, i.e. $0 < \phi < \frac{\pi}{2}$, **c)** Capacitive load, when $X_L < X_C$ and this case capacitance is partially cancelled by inductance and $Z \angle \phi = \sqrt{R^2 + (X_L - X_C)^2} \angle \tan^{-1} \left(-\frac{X_L - X_C}{R}\right)$, where $\phi = \tan^{-1} \left(-\frac{X_L - X_C}{R}\right)$, i.e. $0 > \phi > -\frac{\pi}{2}$ or, ϕ is -ve in the range.

Summary of AC Circuits

V-R Circuit	V-L Circuit	V-C Circuit	V-RLC Circuit
$\bar{I} = \frac{\bar{V}}{\bar{R}} = \frac{V \angle \theta_v}{R \angle 0} = \frac{V}{R} \angle \theta_v$	$\bar{I} = \frac{\bar{V}}{\bar{X}_L} = \frac{V \angle \theta_v}{X_L \angle \frac{\pi}{2}} = \frac{V}{X_L} \angle \left(\theta_v - \frac{\pi}{2}\right)$	$\bar{I} = \frac{\bar{V}}{\bar{X}_C} = \frac{V \angle \theta_v}{X_C \angle -\frac{\pi}{2}} = \frac{V}{X_C} \angle \left(\theta_v + \frac{\pi}{2}\right)$	$\bar{I} = \frac{\bar{V}}{\bar{Z}} = \frac{V \angle \theta_v}{Z \angle \phi} = \frac{V}{Z} \angle (\theta_v - \phi)$
Current in phase with voltage	Current in lagging voltage at an angle $\frac{\pi}{2}$	Current in leading voltage at an angle $\frac{\pi}{2}$	Current could be lagging voltage at an angle ϕ . <ul style="list-style-type: none"> • ϕ is (+)ve if $X_L > X_C$ • ϕ is (-)ve if $X_L < X_C$ • ϕ is Zero if $X_L = X_C$
$\bar{Z} = R + j0 = Re^{j0}$	$\bar{Z} = 0 + jX_L = X_L e^{j\frac{\pi}{2}}$	$\bar{Z} = 0 - jX_C = X_C e^{-j\frac{\pi}{2}}$	$\bar{Z} = R + j(X_L - X_C) = \sqrt{R^2 + (X_L - X_C)^2} e^{j\phi}$; $\phi = \angle \tan^{-1} \frac{X_L - X_C}{R}$
Power Factor=1	Power Factor =0	Power Factor =0	Power Factor =cos ϕ

Resonance and Damping: Behaviour of a typical series of a RLC circuit at different frequencies is shown in the figure, where $L = 10\text{mH}$ and $C = 100\mu\text{F}$. Variation of X_L , X_C and X with frequency over a range from 50 Hz to 500 Hz has been plotted. Corresponding variation of current with Two values of resistance $R = 1\Omega$ and $R = 5\Omega$, from a source of 50V, with variable frequency, has also been shown in the figure. Equivalent reactance of the circuit is $X = X_L - X_C$, where variation in $X_L = \omega L = 2\pi fL$; it is proportional to frequency, while variation in $X_C = \frac{1}{\omega C}$; it is inversely proportional to frequency, and being anti-phase to X_L is shown in VIth

quadrant. The point of intersection of X with frequency axis is $2\pi fL = \frac{1}{2\pi fC} \rightarrow f = \frac{1}{2\pi\sqrt{LC}}$ and is called **Frequency of Resonance**. Adjusting value of inductance or capacitance in the circuit to obtain any desired resonant frequency is called **Tuning of Circuit**. At resonant frequency, there is cyclic exchange of energy in magnetic field in inductance is completely with the energy in electric field of capacitor, and no energy is exchanged by either the inductor or the capacitor with the source. Nevertheless, energy dissipated by resistance due to flow of current through it is supplied by the source, and eventually power factor of the circuit at resonant frequency is Unity. In the instant case resonant frequency is ≈ 150 Hz.

It is to be noted that magnitude of current increases sharply with the decrease of resistance R in the circuit. Hypothetically, in the event of $R \rightarrow 0$, current drawn by the circuit would tend to ∞ , and capable of damage to the circuit.

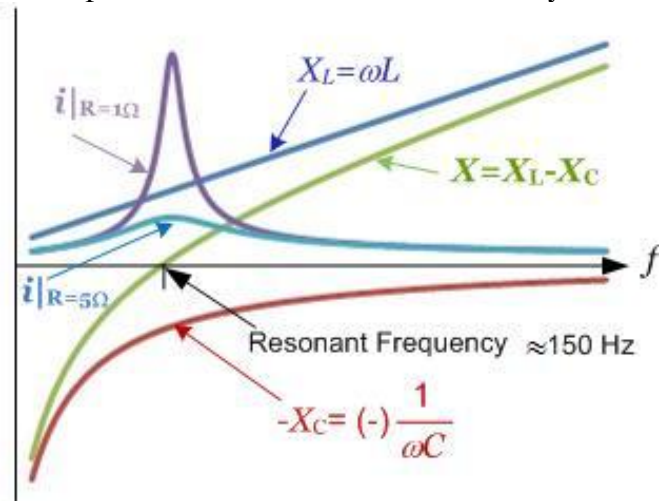

Resonant circuits have wide application in not only in electronic and communication, but also in operation and safety of power system.

Transformer: This is the most versatile equipment in electrical systems, which helps in transfer of power from point of generation, at low voltage, to a distant point at high voltage. Since power $P = VI$, therefore, with the increase of voltage there is decrease of current. This low current offers advantage of saving in cost of material, and power loss ($= I^2R$). Transformer is a static device and an excellent application of the principle of mutual inductance. An ideal Two-winding transformer is shown in the figure mounted on a magnetic core. The winding connected to source is called **Primary Coil**, and the other connected to load (R) is called **Secondary Coil**. Principle of transformer is analyzed in three cases.

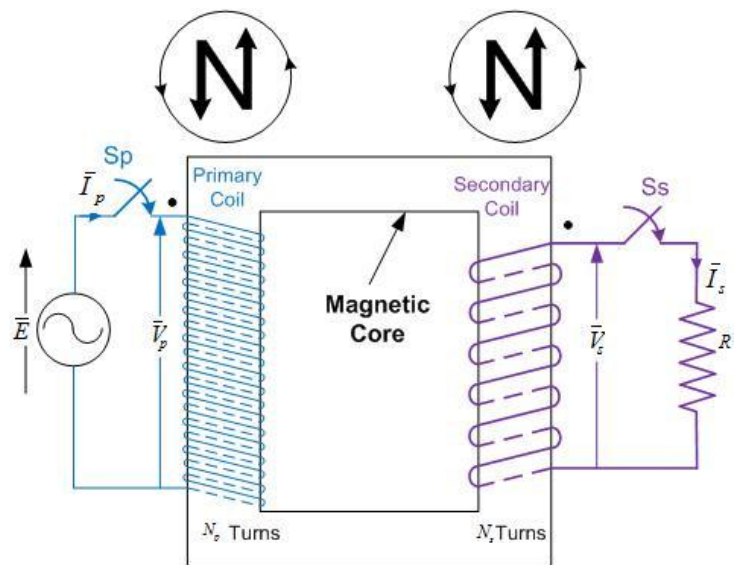

Case I: Primary coil is disconnected from source, (switch **S_p** is open). In this case since there is no flow current, there would be no flux and therefore it is just an inactive core coil assembly, where switch connecting load (**S_s**) is open or closed does not make any difference.

Case II: Switch '**S_s**' is open and switch '**S_p**' is closed and transients have settled. In this case applying KVL, loop voltage equation would be $\bar{E} - \bar{V}_p = \bar{E} - \bar{I}_m \bar{X}_p = 0$, here, I_m is the magnetizing current and vectorially it can be expressed as shown in the figure. Magnetizing current is generally very small, while magnitude of Primary voltage is equal to source voltage i.e. $V_p \approx E$. It leads to $V_p = -\frac{d\psi}{dt} = -N_p \frac{d\phi}{dt}$. Since E is sinusoidal and hence corresponding ϕ would also be sinusoidal. Accordingly, coefficient of maximum ϕ , which corresponds E , would vary between in the range of -1 to 1 . Moreover, in transformer, primary coil is mounted on a magnetic core, closed in shape, it would have very small of coil reluctance (\mathcal{R}), considered to be negligible and conversely relative permeability is very large. Thus, current (I_m) through the coil would be negligible since $\phi = \frac{N_p I_m}{\mathcal{R}}$. In any case $I_m \neq 0$, for V_p to exist, otherwise it would reduce to Case I. Ideally, magnetic flux ϕ would take a closed path through magnetic core, and hence entire flux would also link with the secondary

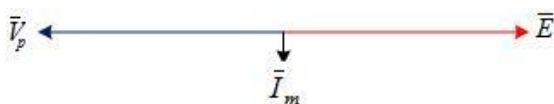

coil. Accordingly, voltage induced in secondary coil would be $V_p = -N_s \frac{d\phi}{dt}$. In ideal transformer, resistance of primary coil is negligible as compared to its inductance and hence I_m would lag behind applied voltage by an angle 90° , and is shown in the figure. Voltage equation for primary and secondary coils have a common factor $(-)\frac{d\phi}{dt}$, which is constant since voltage of source E is constant. Thus, it leads to an important inference $\frac{V_p}{V_s} = \frac{N_p}{N_s}$ called **Transformation Ratio (TR)**, and \bar{V}_p and \bar{V}_s are in phase.

Case III: Switch **Ss** is closed on resistance R , and transients have settled down. Since, load connected to the secondary coil is resistive, it would draw a current $\bar{I}_s = \frac{\bar{V}_s}{R}$ in phase with \bar{V}_p . In analysis of transformer, voltage of secondary coil is normalized by taking $TR = 1$. This eventually leads to $V_p \rightarrow V_s$,



and, therefore, to avoid confusion coil voltages are represented as V . In an additional modification in vector diagram for this case I_m is ignored being negligible. Once current is supplied to R by secondary coil, as per Lenz's Law it would tend to cause it generation i.e. ϕ . This would in turn reduce ϕ in the core and as a consequence, V_p would also reduce. This would cause an increase in current in the primary coil in accordance

with voltage equation $\frac{\bar{E} - \bar{V}_p}{X_p} = \bar{I}_p$. This increase would correspond to cancellation of flux by current in secondary coil and to restore flux in the core to its initial value ϕ . Since, $\phi = \frac{MMF}{\mu r}$, this can happen only if $N_p I_p = N_s I_s$, and

is called **MMF balance** caused by current through windings of transformer. It leads to $\frac{I_p}{I_s} = \frac{N_s}{N_p} = \frac{1}{TR}$. Using

the TR determined in case II it turns to $\frac{V_p}{V_s} = \frac{I_s}{I_p} = TR$, or, $V_p I_p = V_s I_s = S$. Here, **S** is called **Capacity of**

Transformer, an AC equipment, and its unit is **Volt-Ampere or Kilovolt-Ampere** and not Watts or Kilowatt.

An important point needs elaboration is determination of the notional polarity of primary and secondary coils represented by a dot (·) in the figure of transformer. Notional polarity of the primary coil is the point of input, while notional polarity of the secondary coil depends upon the direction of its winding, relative to the primary coil. In the given configuration, seeing from the top, direction of winding of primary coil is in anti-clockwise direction, while secondary coil is in clock-wise direction. Hence, notional current through primary coil would produce North Pole at the top. In order to maintain MMF Balance, current through secondary coil shall have to be such that create flux which opposes flux created by current in primary winding. This is possible only when direction current through of secondary coil is also anti-clockwise. Eventually with this direction of current in secondary coil current would leave it from top and enter from bottom. This leads to node of secondary coil on the top as shown with the dot (·). This concept of node is extremely useful in analysis of Mutli-Winding Transformers, which is outside the scope of this manual. Readers inquisitive readers are welcome to write through [Contact Us](#).

Types of Transformer: Transformers are of various types and this classification depends upon their transformation ratio, voltage rating, construction, and uses. At this stage classification is made on transformation ratio and its uses.

In case $TR > 1$ it would lead to secondary voltage, across secondary coil proportionately lower than primary voltage, across primary coil, and is called **Step-Down Transformer**. Whereas, for $TR < 1$ it will provide secondary voltage higher than primary voltage and is called **Step-Up Transformer**.

Transformers find application from electronic devices to electrical network used for supply of power all across the country and even trans-countries. In this context, transformer used for converting voltage level of electrical power, critical application and most widely in use, are called **Power Transformers**.

Efficiency of Transformer: As per definition of efficiency (η), it is ratio of out power to input power, and is equally valid for transformer also and for an ideal transformer it should be one, since this idealization is based on coils having Zero or negligible resistance. Nevertheless, this assumption is not valid in practical cases and

hence $\eta = \frac{V_s I_s \cos \theta_s}{V_p I_p \cos \theta_p}$, which involves impedance loads $\bar{Z} = R + jX$, where $R \neq 0$, and $X \neq 0$, and so also both primary and secondary coils have resistances are non-Zero. This analysis is beyond scope of this manual. Nevertheless, inquisitive readers welcome to know more about it through [Contact Us](#)

Some interesting questions: Transformers form the core of electrical network and every beginner confronts two conceptual questions – **a) Can transformer connected to AC Circuit?** and **b) Can step-up transformer be used infinitely, in a cascaded formation, to compensate voltage drop in supply circuit?**

Answers to both the questions are NO. In first case reason is that transformer is an inductive device which acts as short-circuit to DC supply. Therefore, after the transients settle down, it would offer a resistance corresponding to that of its primary coil. In turn it would draw a dangerously very high current. Reason for the second case is that a transformer, as the name suggests, transfers power from primary to secondary coil, through magnetic linking provided by the core. Thus power drawn from the base source, is dependent on its capacity. Moreover, it is not possible to have an ideal network with Zero Resistance-Zero Loss and therefore, it cannot breach power capacity of the source. Along with this, secondary current reflected on primary would tend to add up with every stage of cascading of transformer. Eventually, at some stage either it would exceed VA capacity of either feeding transformer or the base source of power. Thus it would prohibit infinite cascading.

Summary: This part concludes Electricity and Magnetism, with AC Circuits and transformers; the concepts most widely in use in day-to-day life. Understandings of Electricity and Magnetism needs to be reviewed since phenomenon elaborated in this are totally conceptual and not available for direct observation, It is only effects and there inferences that goes to firm up the concepts. Inquisitive readers are welcome to raise their queries, doubts or suggestions and keenness beyond the contents, through [Contact Us](#).

Solving of problems, is an integral part of a deeper journey to make integration and application of concepts intuitive. This is absolutely true for any real life situations, which requires multi-disciplinary knowledge, in skill for evolving solution. Thus, problem solving process is more a conditioning of the thought process, rather than just learning the subject. Practice with wide range of problems is the only pre-requisite to develop proficiency and speed of problem solving, and making formulations more intuitive rather than a burden on memory, as much as overall personality of a person. References cited below provide an excellent repository of problems. Readers are welcome to pose their difficulties to solve any-problem from anywhere, but only after two attempts to solve. It is our endeavour to stand by upcoming student in their journey to become a scientist, engineer and professional, whatever they choose to be.

Looking forward, these articles are being integrated into Mentors' Manual. After completion of series of such articles on Physics, representative problems from contemporary text books and Question papers from various competitive examinations shall be drawn and supported with necessary guidance to evolve solutions as a dynamic exercise which is contemplated to accelerate the conceptual thought process.

References:

1. NCERT; PHYSICS, Text Book for Class XI (Part I and II), and Exemplar Problems.
2. भौतिक शास्त्र, कक्षा ११ एवं १२,, मध्य प्रदेश पाठ्यपुस्तक निगम, 2016
3. S.L.Loney; The Elements of Statics and Dynamics: Part 1 – Statics and Part 2 – Dynamics.
4. H.C. Verma; Concepts of Physics, (Vol 1 & 2).
3. Resnick, Halliday, Resnick and Krane; Physics (Vol I and II).
4. Sears & Zemansky; University Physics with Modern Physics.
5. I.E. Irodov; Problems in General Physics.

Author is Coordinator of this initiative Gyan-Vigyan Sarita. e-Mail ID: subhashjoshi2107@gmail.com

—00—

According to our philosophers, freedom is the goal. Knowledge cannot be the goal, because knowledge is a compound. It is a compound of power and freedom, and it is freedom alone that is desirable. That is what men struggle after.

- Swami Vivekananda

GROWING WITH CONCEPTS - Chemistry

SECOND LAW OF THERMODYNAMICS

Kumud Bala

Limitations of the first law of thermodynamics:- A major limitation of the first law of thermodynamics is that it merely indicates that in any process, there is an exact equivalence between the various forms of energies involved but it provides no information concerning the spontaneity or feasibility of the process, i.e., whether the process is possible or not. For example, the first law does not indicate whether heat can flow from a cold end to a hot end or not. Similarly, the first law does not tell whether a gas can diffuse from low pressure to high pressure or water can itself run uphill etc.

The answers to the above observations are provided by the second law of thermodynamics. However, before we take up different statements of the second law of thermodynamics, it is important to know what we understand by a 'spontaneous process'.

Spontaneity:- Spontaneity means the feasibility of a process i.e., whether the process is possible or not. Let us consider the following two processes:

- (i) Dissolution of sugar in water at room temperature.
- (ii) Burning of coal in air or oxygen

The first process takes place by itself, although it may be slow. The second process cannot take place by itself. It needs initiation i.e., we have to bring a flame near the coal to start its burning. But once it starts burning, it goes on by itself without the help of any external agency. Both the above processes are spontaneous processes. Hence, a spontaneous process may be defined as a process which can take place either of its own or under some initiation or A process which under some given conditions may take place by itself or by initiation independent of the rate is called a spontaneous process or A spontaneous process is simply a process which is feasible. For more clear understanding, a few more examples of the spontaneous processes are as follows:

- A. Examples of processes which take place by themselves: (i) Dissolution of common salt in

water (ii) Evaporation of water in an open vessel (iii) Cooling down of a cup of tea (iv) Flow of water down a hill (v) Combination of nitric oxide and oxygen to form nitrogen dioxide

$2\text{NO}_g + \text{O}_{2(g)} \rightarrow 2\text{NO}_{2(g)}$ (vi) Combination of hydrogen and iodine to form hydrogen iodide

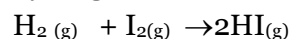

- B. Examples of processes which take place on initiation: (i) A candle made up of wax burns only when ignited. (ii) Heating of calcium carbonate to give calcium oxide and dioxide (initiated by heat) : $\text{CaCO}_{3(s)} \rightarrow \text{CaO}(s) + \text{CO}_{2(g)}$ (iii) Combination of hydrogen and oxygen to form water when initiated by passing an electric spark: $\text{H}_{2(g)} + \text{O}_{2(g)} \rightarrow \text{H}_2\text{O}(l)$ (iv) Acetylene burns brightly only upon heating with oxygen: $\text{C}_2\text{H}_2(g) + \frac{5}{2}\text{O}_2(g) \rightarrow 2\text{CO}_2(g) + \text{H}_2\text{O}(l)$

A process which can neither take place by itself nor by initiation is called a non-spontaneous process. Examples, (i) Flow of water up a hill (ii) Flow of heat from a cold body to a hot body. (iii) Diffusion of gas from low pressure to a high pressure (iv) Dissolution of sand in water.

The driving force for a spontaneous process: Why some processes are spontaneous? Obviously, there must be a force which drives the process or a reaction in a particular direction. This force which is responsible for spontaneity of a process is called the driving force.

Let us now see what is the nature of the driving force?

- (1) **Tendency for minimum energy:** It is a common observation that in order to acquire maximum stability, every system tends to have minimum energy. For example, (i) A stone lying at a height has a tendency to fall

down so as to have minimum potential energy. (ii) Water flows down a hill to have minimum energy. (iii) A wound watch spring has tendency to unwind itself to decrease its energy to minimum. (iv) Heat flows from hot body to cold body so that heat content of the hot body becomes minimum. Thus all the above process are spontaneous because they have a tendency to acquire minimum energy. Again, let us consider the following exothermic reactions; all of which are spontaneous:

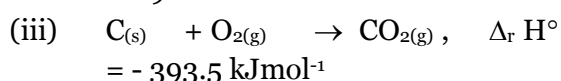
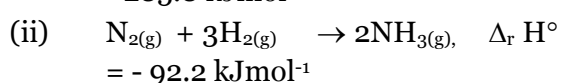
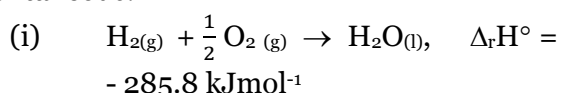

All these reactions are accompanied by evolution of heat. In other words, the heat content of the products is less than those of the reactants. Hence, one may conclude that a tendency to attain minimum energy, i.e., a negative value of enthalpy change, ΔH , might be responsible for a process or a reaction to be spontaneous or feasible.

Limitations of the criterion for minimum energy – the above criterion fails to explain the following:

- a. A number of reactions are known which are endothermic, i.e., for which ΔH is positive but still they are spontaneous, e.g., (i) Evaporation of water or melting of ice. It takes place by absorption of heat from the surroundings. $H_{2O(l)} \rightarrow H_{2O(g)}$, $\Delta_{\text{vap}} H^\circ = +40.8 \text{ kJmol}^{-1}$ $H_{2O(s)} \rightarrow H_{2O(l)}$, $\Delta_{\text{fus}} H^\circ = +6.0 \text{ kJ mol}^{-1}$ (ii) Dissolution of salts like NH_4Cl , KCl etc. $NH_4Cl_{(s)} + aq \rightarrow NH_4^+_{(aq)} + Cl^-_{(aq)}$, $\Delta_{\text{sol}} H^\circ = +15.1 \text{ kJmol}^{-1}$ (iii) Decomposition of calcium carbonate on heating $CaCO_{3(s)} \rightarrow CaO_{(s)} + CO_{2(g)}$ $\Delta_r H^\circ = +177.8 \text{ kJ mol}^{-1}$ (iv) Decomposition of N_2O_5 at room temperature. $N_2O_{5(g)} \rightarrow 4NO_{2(g)} + O_{2(g)}$, $\Delta_r H^\circ = +219.0 \text{ kJmol}^{-1}$.

- b. A number of reactions are known for which ΔH is zero but still they are spontaneous, e.g., (i) Reaction between acetic acid and ethyl alcohol $CH_3COOH_{(l)} + C_2H_5OH_{(l)} \rightarrow CH_3COOC_2H_5_{(l)} + H_2O_{(l)}$ (ii) Expansion of an ideal gas into vacuum. If an insulated vessel containing an ideal gas is connected to an insulated vessel which has been completely evacuated and the stop-cock connecting the two is opened, the expansion is spontaneous but no energy change takes place. This is because energy change can take place either as heat or as work. In this case, as vessels are insulated, $q=0$. Further, work done, $w=-P_{\text{ext}} \times \Delta V$. As $P_{\text{ext}} = 0$, therefore, $w = 0$. Hence, by first law of thermodynamics, $\Delta U = q + w = 0 + 0 = 0$.
- c. Even those reactions for which ΔH is negative, rarely proceed to completion even though ΔH remains negative throughout.
- d. Reversible reactions also occur. For example, the reaction $H_{2(g)} + I_{2(g)} \rightarrow 2HI_{(g)}$ having $\Delta H = +ve$ and the reverse reaction, viz., $2HI_{(g)} \rightarrow H_{2(g)} + I_{2(g)}$ having $\Delta H = -ve$ both occur, i.e., are spontaneous. Hence, it may be concluded that the energy factor or enthalpy factor cannot be the sole criterion for predicting the spontaneity or the feasibility of a process. Thus, some other factor must also be involved. This factor is the tendency for maximum randomness.

(2) Tendency for maximum randomness:

Let us consider a process which is spontaneous but for which $\Delta H = 0$. Since for such a process, energy factor has no role to play, so we shall be able to find out the other factor which makes the process spontaneous. A simple case of such a process is 'mixing of two gases' which do not react chemically. Suppose the two gases are enclosed in bulbs A and B connected to each other by a tube and kept separated by a stop-cock. Now, if the stopcock is opened, the two gases mix

completely. The gases which were confined to bulbs A and B separately are no longer in order. Thus, a disorder has come in or in other words, the randomness of the system has increased.

Another excellent example of a spontaneous process for which $\Delta H = 0$ is the spreading of a drop of ink in a beaker filled with water. Thus, it may be concluded that the second factor which is responsible for the spontaneity of a process is the tendency to acquire maximum randomness. This factor helps to explain the spontaneity of the endothermic processes as follows: (i) Evaporation of water takes place because the gaseous water molecules are more random than the liquid water molecules. In other words, the process is spontaneous because it is accompanied by increase of randomness. Similarly, melting of ice is a spontaneous process because liquid state is more random than the solid state. (ii) Dissolution of ammonium chloride is spontaneous because in the solid, the ions are fixed but when they go into the aqueous solution, they are free to move about. In other words, the process is accompanied by an increase of randomness. (iii) Decomposition of solid calcium carbonate is spontaneous because the gaseous CO_2 produced is more random than the solid CaCO_3 . (iv) Decomposition of N_2O_5 is spontaneous because 2 moles of gaseous N_2O_5 give 5 moles of gaseous products. Hence, the process is accompanied by increase of randomness.

Limitation of the criterion for maximum randomness:- It is important to mention here that just as the energy factor (ΔH) cannot be the sole criterion for determining the spontaneity of a process, similarly, the randomness factor also cannot be the sole criterion for the spontaneity of a process. This is obvious from the fact that if the randomness factor were the only criterion, then the processes like liquefaction of a gas or solidification of a liquid would not have been feasible, since these were accompanied by

decrease of randomness. Thus, it may be concluded that the overall tendency for a process to be spontaneous will depend upon both the factors.

Overall tendency as the driving force for a process: The overall tendency for a process to occur depends upon the resultant of the following two tendencies:

- (i) Tendency for minimum energy
- (ii) Tendency for maximum randomness

The resultant of the above two tendencies which gives the overall tendency for a process to occur is called the driving force of the process.

Hypothetical process: To understand the conditions under which the process will be spontaneous or non-spontaneous, let us consider a hypothetical process $A \rightarrow B$. Suppose 'E' represents the tendency for minimum energy, 'R' represents the tendency for maximum randomness and 'D' represents the overall tendency (i.e., the driving force) which is the resultant of E and R. Then the following different possibilities arise:

Type 1: When the net driving force is in the forward direction

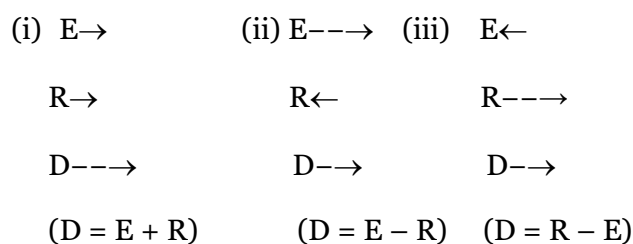

- (i) Both E and R favour the forward process. The net driving force is very large and favours the forward process.
- (ii) E favours R opposes but $E > R$ so that the net driving force, though small, favours the forward process.
- (iii) E opposes and R favours but $R > E$, so that the net driving force is again in the forward direction.

In all the above three cases, since the driving force is in the forward direction, therefore, under any of the above conditions, the process will be

spontaneous. Further, it may be noted that whereas processes (i) and (ii) are exothermic, the process (iii) is endothermic.

Type 2: When the net driving force is in the backward direction

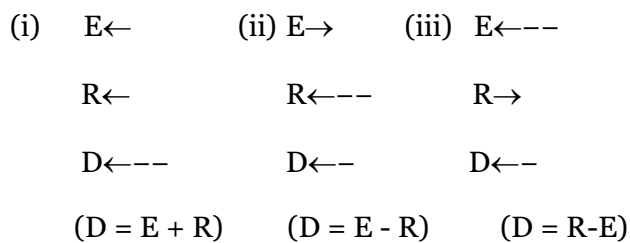

- (i) Both E and R oppose
- (ii) E favours and R opposes but R>E
- (iii) E opposes and R favours but E>R

Type 3: When the net driving force is zero

Type 4: E favours, R opposes but E=R



Type 5: E opposes, R favours but E=R

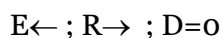

In all the above five cases (Type 2 and Type 3), the process is non-spontaneous. Further, whereas processes (i), (iii) and (v) are endothermic, the processes (ii) and (iv) are exothermic.



Author is M.Sc. (Chem.), M.Ed. and Advanced Diploma in German Language (Gold Medallist). She retired as a Principal, Govt. School Haryana, has 3-1/2 years' experience in teaching Chemistry and distance teaching through lectures on Radio and Videos. She has volunteered to complement mentoring of students for Chemistry through Online Web-enabled Classes of this initiative.
e-Mail ID: kumud.bala@yahoo.com

—OO—

[Answers to Science Quiz in July'17](#)

Kumud Bala

1. (b), 2. (a), 3. (a), 4. (a), 5. (a), 6. (a), 7. (b), 8. (a), 9. (a), 10. (c),
11. (a), 12. (c), 13. (b), 14. (b), 15. (b), 16. (a), 17. (a), 18. (b), 19. (a), 20. (c)

—OO—

In the light of the above discussion, let us now explain the spontaneity of a few processes, e.g.,

1. Evaporation of water. $H_2O_{(l)} \rightarrow H_2O_{(g)}$, $\Delta H = +44 \text{ kJ mol}^{-1}$.

In this process, E opposes (process being endothermic), R favours (because gas is more random than liquid). Since the process is known to be spontaneous, hence R must be greater than E (R>E).

2. Dissolution of NH_4Cl in water. $NH_4Cl_{(s)} + aq \rightarrow NH_4^+_{(aq)} + Cl^-_{(aq)}$, $\Delta H = +15.1 \text{ kJ mol}^{-1}$ in this process, E opposes and favours. Here again, the spontaneity of the process is explained by suggesting that R>E.
3. Reaction between H_2 and O_2 to form H_2O . $H_{2(g)} + \frac{1}{2} O_{2(g)} \rightarrow H_{2O(l)}$, $\Delta H = -286.2 \text{ kJ mol}^{-1}$. Here, E favours (the reaction being exothermic) but R opposes (because liquid is less random than the gases). However, since the process is experimentally known to be spontaneous, we must have E>R.
4. Decomposition of $CaCO_3$ on heating: $CaCO_{3(s)} \rightarrow CaO_{(s)} + CO_{2(g)}$, $\Delta H = +177.8 \text{ kJ mol}^{-1}$. Here, E opposes but R favours. Thus, to explain the spontaneity of the process, we must have R>E.

SCIENCE QUIZ- Aug'17

Kumud Bala

- Calculate the result of 15. -0.072 to proper number of significant figures:
(A) 15. (B) 14.928 (C) 14.9 (D) 14.93
- Calculate to the proper number of significant figures: $58.0 + 0.0035 + 0.00002$
(A) 58.00352 (B) 58.0035 (C) 58 (D) 58.0
- The S.I unit of pressure is :
(A) Ttorr (B) Atmosphere
(C) Pascal (D) Dynes per square metre
- The prefix femto stands for
(A) 10^9 (B) 10^{-12} (C) 10^{15} (D) 10^5
- How many times is a kg heavier than a mg?
(A) 10^3 (B) 10^5 (C) 10^6 (D) 10^9
- 22.4 L of a gas corresponds to
(A) 22.4 m^3 (B) 2.24 m^3
(C) $2.24 \times 10^{-2} \text{ m}^3$ (D) $2.24 \times 10^2 \text{ m}^3$
- According to Dalton's atomic theory, the smallest particle in which matter could exist is called
(A) an atom (B) an electron
(C) a molecule (D) a proton
- The ratio of mass of 1 mole of sodium and 10^{23} atoms of sodium is:
(A) 6.02 (B) 23
(C) $\frac{23}{6.02}$ (D) 23×6.02
- The volume of 1.0 g of hydrogen at N.T.P. is
(A) 1.12 L (B) 11.2 L
(C) 22.4 L (D) 2.24 L
- 1 mole of methane (CH_4) contains
(A) 6.02×10^{23} atoms of H
(B) 4 gm atoms of hydrogen
(C) 1.81×10^{23} molecules of methane
(D) 3.0 g of carbon
- One a.m.u. has the mass equal to:
(A) $1.66 \times 10^{-22} \text{ g}$ (B) 1.66×10^{-24}
(C) 1g (D) 1/12g
- One mole of CO_2 corresponds to:
(A) 22.4 L at 1 atm. and 25°C
(B) 44g (C) 1g
(D) 6.02×10^{23} C-atoms and 6.02×10^{23} O-atoms
- Which of the following properties changes with valency?
(A) equivalent weight (B) atomic weight
(C) molecular weight (D) density
- One mole of hydrogen peroxide (H_2O_2) has a mass same as that of
(A) 0.1 mol of sucrose ($\text{C}_{12}\text{H}_{22}\text{O}_{11}$)
(B) 2.0 mol of ammonia
(C) 11.2L of SO_2 at N.T.P.
(D) 0.1 mol of SO_3
- How many moles of helium gas occupy 22.4L at 0°C and 1 atm. pressure?
(A) 0.11 (B) 0.90 (C) 1.0 (D) 1.11
- Number of molecules in 1L of water is approximately
(A) $6.02 \times 10^{23} / 18$ (B) $18 \times 6.02 \times 10^{23}$
(C) $55.5 \times 6.02 \times 10^{23}$ (D) $\frac{22.4}{18} \times 6.02 \times 10^{23}$
- The average weight of an Indian male is 150 pounds. In SI units it is equal to
(A) 68.1kg (B) 75.0 kg (C) 45.4 kg (D) 72-2kg
- One litre of an unknown gas weighs 1.25g at NTP. The possible formula of the gas is :
(A) NO (B) CO (C) SO_2 (D) O_2
- Which has maximum number of atoms?
(A) 24g of C(12) (B) 56g of Fe (56)
(C) 27g of Al (27) (D) 108g of Ag (108)
- Which of the following numbers has three significant figures?
(A) 0.009 (B) 321.00 (C) 1023 (D) 0.0300

(Answers to this Science Quiz – July'17 shall be provided in Supplementary e-Bulletin dt 1st August'17)

Theme Song :

PREMISE: *We are pleased to adopt a song “ इतनी शक्ति हमें देना दाता.....” from a old Hindi Movie Do Aankhen Barah Haath दो आँखें बारह हाथ of year 1957, directed by The Late V. Shantaram. The lyrics are by Shri Bharat Vyas, singer Melody Queen Sushri Lata Mangeshkar, and Music Direction by Vasant Desai. It has become a widely accepted inspirational song and/or prayer in many educational institutions and socially inspired initiatives engaged in mentoring of unprivileged children. This newly formed non-organizational initiative, being selflessly operated by a small set of compassionate persons, finds its philosophy in tune with the song and conveys its gratitude to all the eminent persons who brought out the song in a manner that it has attained an epitome of popularity. While working its mission and passion, the group invites one and all to collectively complement in grooming competence to compete among unprivileged children. The song/prayer goes as under -*

इतनी शक्ति हमें देना दाता, मन का विश्वास कमजोर हो ना
हम चले नेक रस्ते पे हमसे, भूलकर भी कोई भूल हो ना ॥

दूर अज्ञान के हो अंधेरे, तू हमें ज्ञान की रोशनी दे
हर बुराई से बचते रहें हम, जितनी भी दे भली ज़िन्दगी दे
बैर हो ना किसी का किसी से, भावना मन में बदले की हो ना ॥

इतनी शक्ति हमें देना दाता, मन का विश्वास कमजोर हो ना
हम चले नेक रस्ते पे हमसे, भूलकर भी कोई भूल हो ना ॥

हम ना सोचें हमें क्या मिला है, हम ये सोचे किया क्या है अर्पण
फूल खुशियों के बाँटे सभी को, सब का जीवन ही बन जाए मधुबन
अपनी करुणा का जल तू बहा के, कर दे पावन हर एक मन का कोना ॥

इतनी शक्ति हमें देना दाता, मन का विश्वास कमजोर हो ना
हम चले नेक रस्ते पे हमसे, भूलकर भी कोई भूल हो ना ॥



**Together Each Achieves More
(TEAM)**

Every end, so also end of this e-Bulletin, is a pause for a review, before re-continuing of a journey far beyond ...